

Getting Started with the Xilinx Virtex-6 FPGA ML605 Evaluation Kit

UG533 (v1.4) November 15, 2010



Xilinx is disclosing this user guide, manual, release note, and/or specification (the "Documentation") to you solely for use in the development of designs to operate with Xilinx hardware devices. You may not reproduce, distribute, republish, download, display, post, or transmit the Documentation in any form or by any means including, but not limited to, electronic, mechanical, photocopying, recording, or otherwise, without the prior written consent of Xilinx. Xilinx expressly disclaims any liability arising out of your use of the Documentation. Xilinx reserves the right, at its sole discretion, to change the Documentation without notice at any time. Xilinx assumes no obligation to correct any errors contained in the Documentation, or to advise you of any corrections or updates. Xilinx expressly disclaims any liability in connection with technical support or assistance that may be provided to you in connection with the Information.

THE DOCUMENTATION IS DISCLOSED TO YOU "AS-IS" WITH NO WARRANTY OF ANY KIND. XILINX MAKES NO OTHER WARRANTIES, WHETHER EXPRESS, IMPLIED, OR STATUTORY, REGARDING THE DOCUMENTATION, INCLUDING ANY WARRANTIES OF MERCHANTABILITY, FITNESS FOR A PARTICULAR PURPOSE, OR NONINFRINGEMENT OF THIRD-PARTY RIGHTS. IN NO EVENT WILL XILINX BE LIABLE FOR ANY CONSEQUENTIAL, INDIRECT, EXEMPLARY, SPECIAL, OR INCIDENTAL DAMAGES, INCLUDING ANY LOSS OF DATA OR LOST PROFITS, ARISING FROM YOUR USE OF THE DOCUMENTATION.

© 2009–2010 Xilinx, Inc. XILINX, the Xilinx logo, Virtex, Spartan, ISE, and other designated brands included herein are trademarks of Xilinx in the United States and other countries. PCI Express is a trademark of PCI-SIG and used under license. All other trademarks are the property of their respective owners.

Revision History

The following table shows the revision history for this document.

Date	Version	Revision
06/24/09	1.0	Xilinx Preliminary Release.
11/18/09	1.1	Xilinx Initial Release.
12/08/09	1.1.1	Initial Release to the Web.
12/23/09	1.2	<ul style="list-style-type: none">• Added "Getting Started with the Base Reference Design."• Updated Figure 1-1, page 10, Figure 1-2, page 10, and Figure 1-20, page 23.• Miscellaneous typographical edits.
01/22/10	1.2.1	<ul style="list-style-type: none">• Minor typographical edit.
06/07/10	1.3	Revised Figure 1-22, page 24 and Figure 1-29, page 30 .
11/15/10	1.4	Revised "Installing the ISE Software," page 61 describing the use of the software voucher as part of the software registration process.

Table of Contents

Preface: About This Guide

Additional Documentation	5
Additional Support Resources	6
Introduction	7
ML605 Evaluation Kit Contents	7
Key Features	8
Virtex-6 FPGA	8
Configuration	8
Communication and Networking	8
Memory	8
Clocking	8
Input/Output and Expansion Ports	9
Power	9
Getting Started with the Flash Demonstration	9
Board Features	10
Connecting the Cables and Power	11
Setting the System Properties	12
Configuring the FPGA	15
Running the BIST Application	17
Getting Started with PCI Express PIO Demonstration	28
System Requirements, Installation, and Setup	29
Running the PCI Express PIO Demonstration	31
Configuration Registers Test	32
Base Address Register (BAR) Test	38
Getting Started with the Base Reference Design	43
Setting up the Hardware for the Base Reference Design	44
Installing Base Reference Design Application GUI	44
Running the Base Reference Design	55
Installing the ISE Software	61
Redeeming the Software and IP License	62
Now What?	67
Getting Additional Help and Support	68
Support	68
Warranty	69

Appendix A: References

About This Guide

This user guide introduces the Virtex®-6 FPGA ML605 board features, provides instructions for setting up the hardware, and includes step-by-step procedures for verifying the ML605 board functionality.

Additional Documentation

The following documents are also available for download at <http://www.xilinx.com/support/documentation/virtex-6.htm>.

- **Virtex-6 Family Overview**
The features and product selection of the Virtex-6 family are outlined in this overview.
- **Virtex-6 FPGA Data Sheet: DC and Switching Characteristics**
This data sheet contains the DC and Switching Characteristic specifications for the Virtex-6 family.
- **Virtex-6 FPGA Packaging and Pinout Specifications**
This specification includes the tables for device/package combinations and maximum I/Os, pin definitions, pinout tables, pinout diagrams, mechanical drawings, and thermal specifications.
- **Virtex-6 FPGA Configuration Guide**
This all-encompassing configuration guide includes chapters on configuration interfaces (serial and SelectMAP), bitstream encryption, boundary-scan and JTAG configuration, reconfiguration techniques, and readback through the SelectMAP and JTAG interfaces.
- **Virtex-6 FPGA Clocking Resources User Guide**
This guide describes the clocking resources available in all Virtex-6 devices, including the MMCM and PLLs.
- **Virtex-6 FPGA Memory Resources User Guide**
The functionality of the block RAM and FIFO are described in this user guide.
- **Virtex-6 FPGA SelectIO Resources User Guide**
This guide describes the SelectIO™ resources available in all Virtex-6 devices.
- **Virtex-6 FPGA GTX Transceivers User Guide**
This guide describes the GTX transceivers available in all Virtex-6 FPGAs except the XC6VLX760.

- Virtex-6 FPGA Embedded Tri-Mode Ethernet MAC User Guide
This guide describes the dedicated Tri-Mode Ethernet Media Access Controller available in all Virtex-6 FPGAs except the XC6VLX760.
- Virtex-6 FPGA DSP48E1 Slice User Guide
This guide describes the architecture of the DSP48E1 slice in Virtex-6 FPGAs and provides configuration examples.
- Virtex-6 FPGA System Monitor User Guide
The System Monitor functionality available in all Virtex-6 devices is outlined in this guide.
- Virtex-6 FPGA PCB Design Guide
This guide provides information on PCB design for Virtex-6 devices, with a focus on strategies for making design decisions at the PCB and interface level.

Additional Support Resources

To search the database of silicon and software questions and answers or to create a technical support case in WebCase, see the Xilinx website at:

<http://www.xilinx.com/support>.

Getting Started with the Virtex-6 FPGA ML605 Evaluation Kit

Introduction

The Virtex[®] -6 FPGA ML605 Evaluation Kit provides a development environment for system designs that demand high-performance, serial connectivity and advanced memory interfacing. The ML605 is supported by multiple targeted reference designs and the industry-standard FPGA Mezzanine Connector (FMC) that allows scaling and customization with mezzanine cards. Integrated tools help streamline the creation of elegant solutions to complex design requirements. This document provides:

- Introduction to the board's features
- Instruction for default hardware setup
- Step-by-step procedure for verifying the board's functionality

ML605 Evaluation Kit Contents

What is Inside the Box

- Virtex-6 FPGA ML605 Evaluation Board
- Universal 12V power supply
- Two (2) USB A/Mini-B cables (used for download and debug)
- CompactFlash Card
- DVI to VGA Adapter
- Ethernet Cat5 Cable
- ISE[®] Design Suite DVD
 - ◆ A full-seat of Xilinx ISE[®] Design Suite: Logic Edition – Device-Locked to Virtex-6 LX240T FPGA
- ML605 Documentation
 - ◆ Welcome Letter
 - ◆ Hardware Setup Guide
 - ◆ Getting Started Guide

What is Available on the Web

- Product Home Page: www.xilinx.com/ml605
- Reference design user guide, tutorials, and design files
- Schematics, Gerber, and board bill of materials (BOM)
- Additional detailed documentation

Key Features

Virtex-6 FPGA

- XC6VLX240T-1FFG1156 device

Configuration

- Onboard configuration circuitry (USB to JTAG)
- 16 MB Platform Flash XL
- 32 MB Parallel (BPI) Flash
- System ACE™ CompactFlash (CF) controller

Communication and Networking

- 10/100/1000 Tri-Speed Ethernet (GMII, RGMII, SGMII, MII)
- SFP transceiver connector
- GTX port (TX/RX,) with four SMA connectors
- USB to UART Bridge
- USB host port and USB peripheral port
- PCI Express® Gen1 8-lane (x8) and Gen2 4-lane (x4)

Memory

- DDR3 SODIMM (512 MB)
- Linear BPI Flash (32 MB) (Also available for configuration)
- IIC EEPROM (8 Kb)

Clocking

- 200 MHz oscillator (differential)
- 66 MHz socketed oscillator (single-ended)
- SMA connectors for external clock (differential)
- GTX clock port with two SMA connectors

Input/Output and Expansion Ports

- 16x2 LCD character display
- DVI output
- System Monitor
- User pushbuttons (5), DIP switches (8), LEDs (13)
- User GPIO with two SMA connectors
- Two FMC expansion ports
 - ◆ High Pin Count (HPC)
 - Eight GTX transceivers
 - 160 SelectIO™ interface signals
 - ◆ Low Pin Count (LPC)
 - One GTX transceiver
 - 68 SelectIO interface signals

Power

- 12V wall adapter or ATX
- Voltage and current measurement capability of 12V, 2.5V, 1.5V, 1.2V, and 1.0V supplies

Getting Started with the Flash Demonstration

Before installing the software, you can run some of the demonstration designs that are pre-installed on the BPI Flash, Platform Flash, and CompactFlash cards on the ML605 Evaluation Board. These demonstrations provide an overview of the board features. This evaluation kit comes with a number of pre-installed demonstrations and examples, as well as additional reference designs and application notes found on the Xilinx website. The default demonstrations on the Platform Flash and CompactFlash exercise some of the board features including verifying PCI Express connectivity and testing the UART, Ethernet, DDR3, IIC, LEDs, and other commonly used embedded processing features.

Board Features

The ML605 board features are shown in Figure 1-1. The default switch and jumper settings are shown in Figure 1-2.

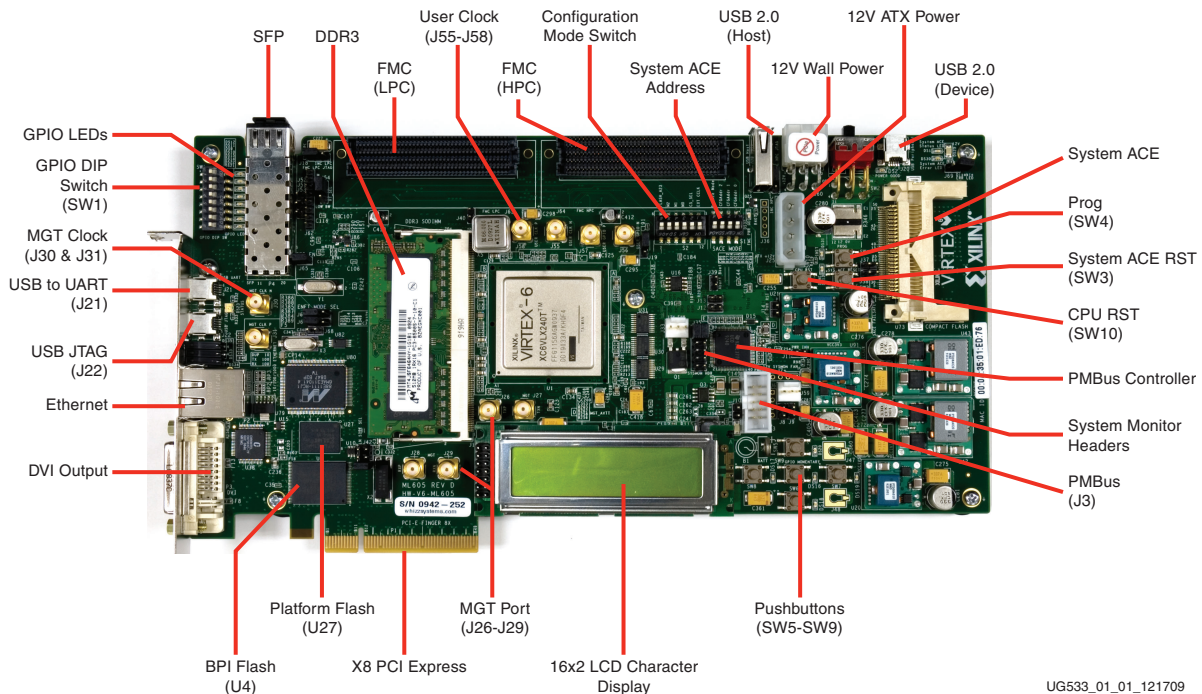

Figure 1-1: Virtex-6 FGPA ML605 Board Features

Ethernet GMII
 J66: Shunt over 1–2
 J67: Shunt over 1–2
 J68: No jumper

FMC Bypass
 J18: Shunt over 1–2 (Bypass FMC LPC)
 J17: Shunt over 1–2 (Bypass FMC HPC)
Note: These are the JTAG chain bypasses for the FMC LPC and FMC HPC connectors.

System Monitor
 J19: Shunt over 1–2
 J35: Shunt over 9–11 and shunt over 10–12

SFP
 J54: Shunt over 1–2 (Full BW)
 J65: Shunt over 1–2 (SFP Enable)

PCIe Lane Size Select
 J42: Shunt over 1–2

System ACE CF Error LED
 J69: Shunt over 1–2

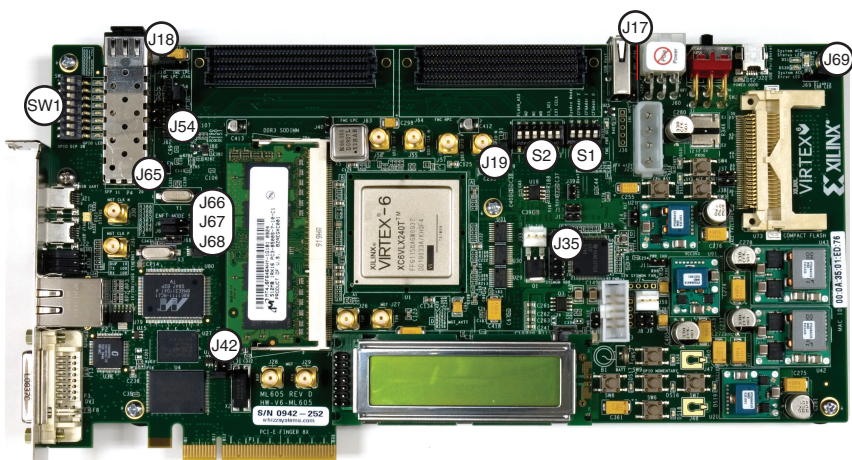

- | | | |
|---------------------------|-----------------------|-------------|
| S1: | S2: | SW1: |
| 4 ON (SysACE Mode = 1) | 6 OFF (FLASH_A23 = 0) | 8 OFF |
| 3 OFF (SysACE Addr 2 = 0) | 5 OFF (M2 = 0) | 7 OFF |
| 2 OFF (SysACE Addr 1 = 0) | 4 ON (M1 = 1) | 6 OFF |
| 1 OFF (SysACE Addr 0 = 0) | 3 OFF (M0 = 0) | 5 OFF |
| | 2 ON (CS_SEL = 1) | 4 OFF |
| | 1 OFF (EXT_CCLK = 0) | 3 OFF |
| | | 2 OFF |
| | | 1 OFF |

UG533_01_02_121709

Figure 1-2: Default Jumper and Switches Settings

Connecting the Cables and Power

The steps in this section outline how to connect the cables and power.

1. Connect one USB Type-A to mini-B 5-pin cables from your PC to J21 on the ML605 board.

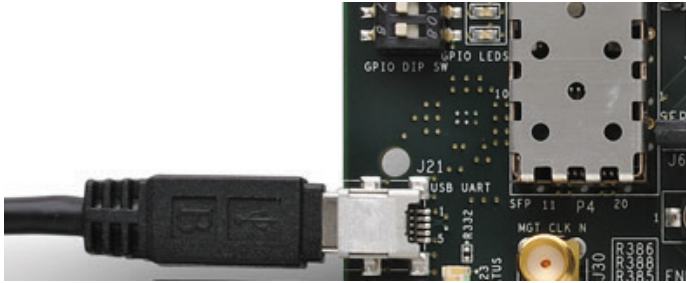
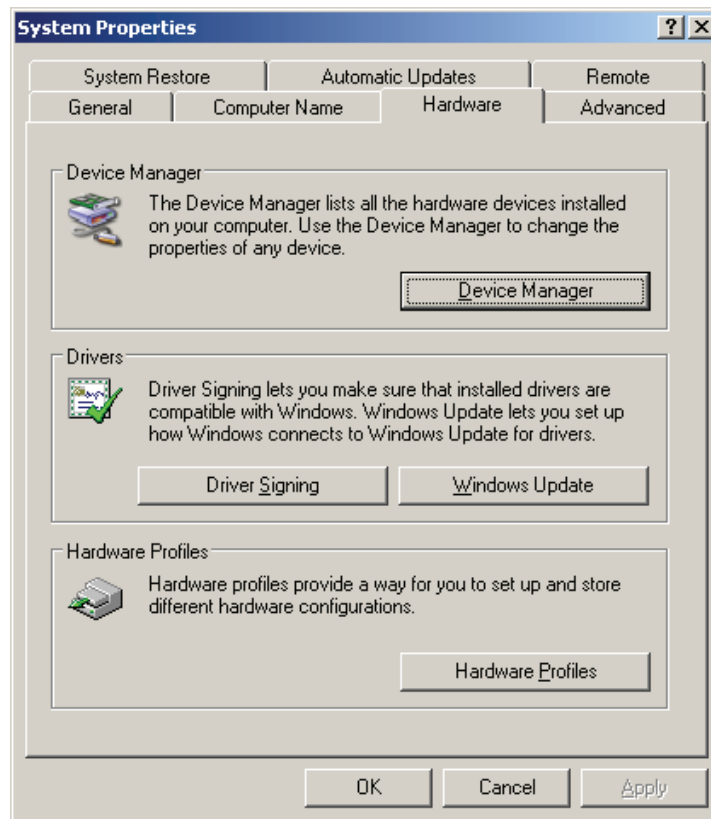

Figure 1-3: Connect the Cables and Power

2. Power on ML605 board for UART Drivers Installation
 - a. Install the CP210x VCP Win2K/XP/2K3 Drivers Server from www.silabs.com.
Note: The drivers are also available on the USB flash drive shipped with the board.

Setting the System Properties

3. Right-click **My Computer** and select **Properties**
 - a. Select the Hardware tab
 - b. Click on **Device Manager**



UG533_01_04_061909

Figure 1-4: Select the Device Manager

4. Expand the Ports Hardware
 - a. Right-click on USB to UART Bridge and select **Properties**.

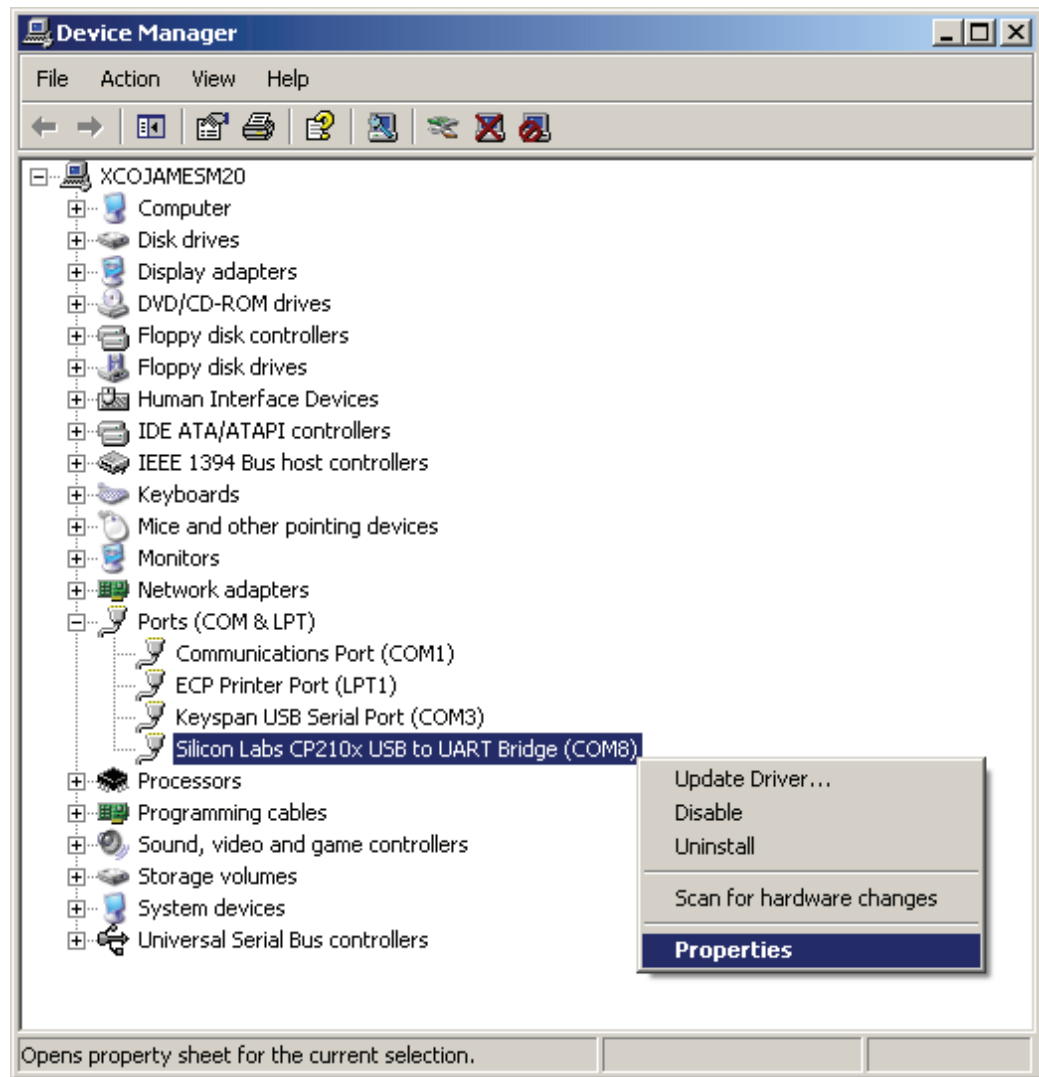

UG533_01_05_061909

Figure 1-5: Select the USB to UART Bridge Properties

5. Under the Port Settings tab
 - a. Click **Advanced**
 - b. Set the COM Port to an open Com Port setting from COM1 to COM4.

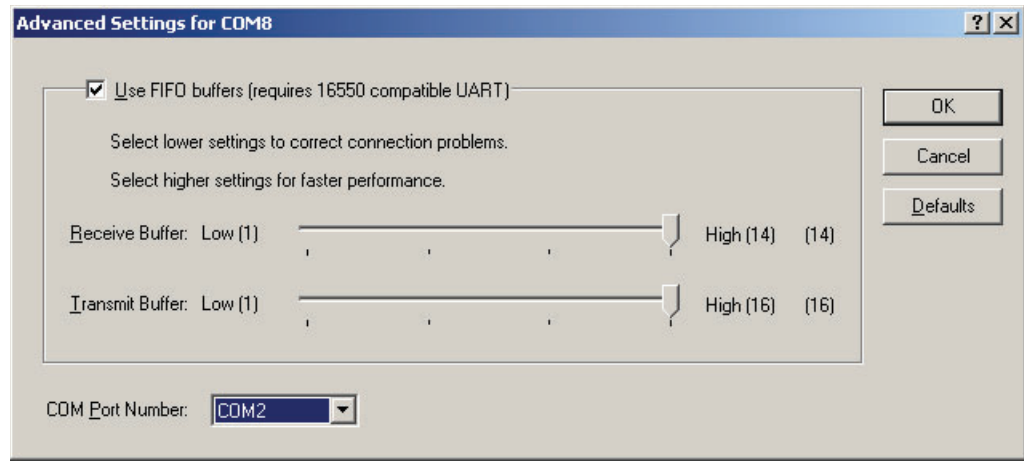

UG533_01_06_061909

Figure 1-6: Set the COM Port

6. Start the Tera Terminal Program (downloadable from <http://www.ayera.com/teraterm>)
 - a. Select your USB com port from the Port drop down window
 - b. Set the baud rate to 9600

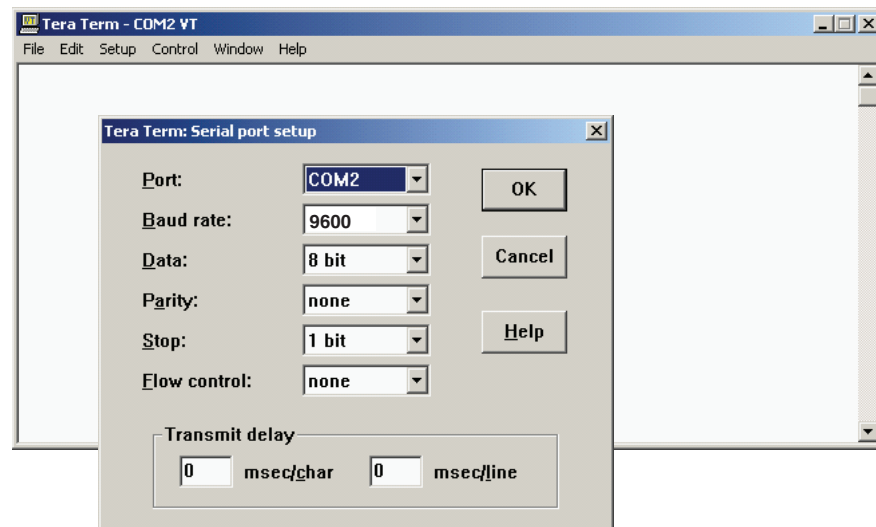

UG533_01_08_111809

Figure 1-7: Set the USG Com Port

Configuring the FPGA

7. Set the DIP switch S1 to 1000 (position 4 to position 1).

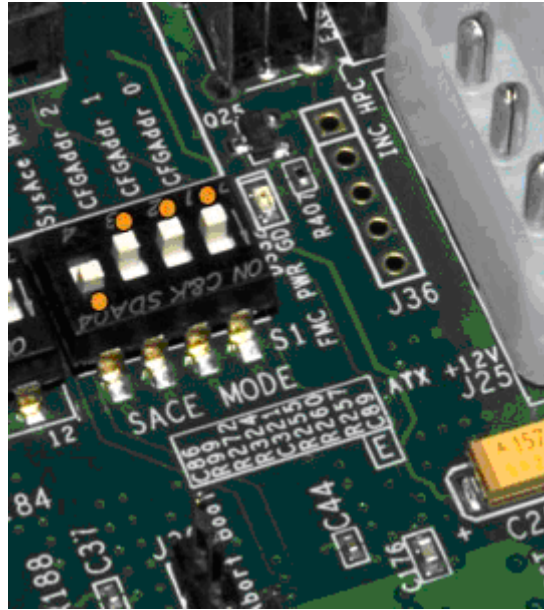

Figure 1-8: Set the DIP Switch

8. Insert the CompactFlash card into the card reader and press SW3, the System ACE Reset pushbutton. The CompactFlash card contains a Built-In System Test (BIST) design which is used for verification of the board's functionality.

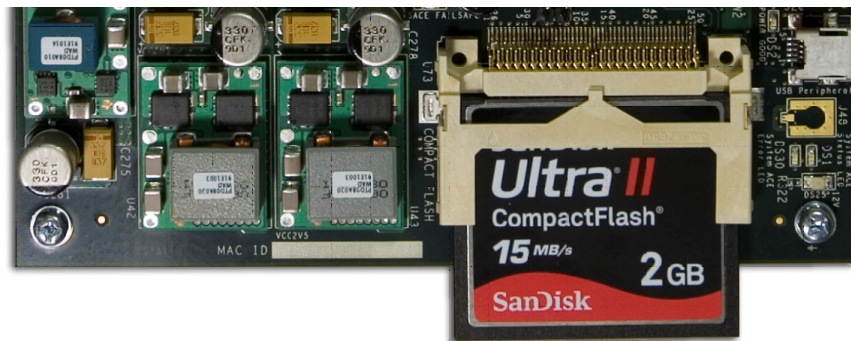
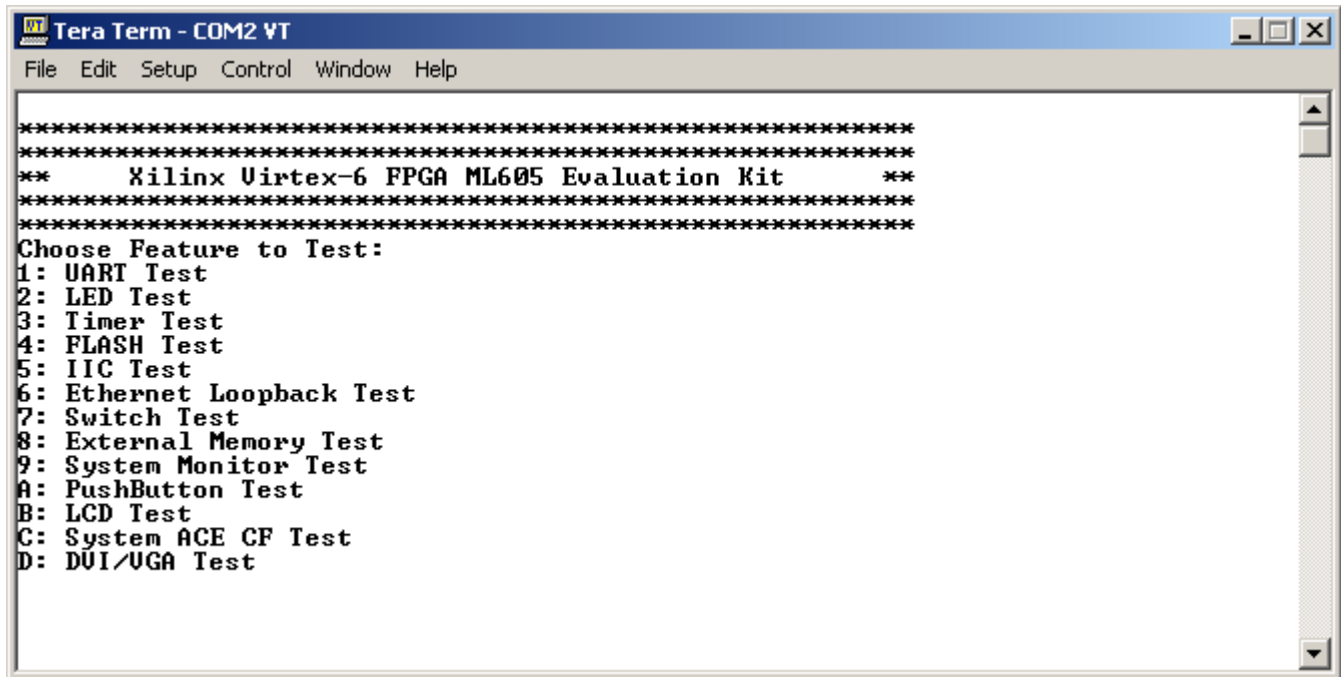

Figure 1-9: Insert the CompactFlash Card

9. After FPGA configuration, a menu of feature tests appears as shown in the Tera Terminal window (Figure 1-10).



```
Tera Term - COM2 VT
File Edit Setup Control Window Help
*****
*****
**      Xilinx Virtex-6 FPGA ML605 Evaluation Kit      **
*****
*****
Choose Feature to Test:
1: UART Test
2: LED Test
3: Timer Test
4: FLASH Test
5: IIC Test
6: Ethernet Loopback Test
7: Switch Test
8: External Memory Test
9: System Monitor Test
A: PushButton Test
B: LCD Test
C: System ACE CF Test
D: DVI/UGA Test
```

Figure 1-10: Initial Test Menu after FPGA Configuration

Running the BIST Application

Typing any number or character between 1 to D makes the bootloader copy the associated software application to the external DDR3 SODIMM memory and run it.

10. Type a **1** to start the UART test.

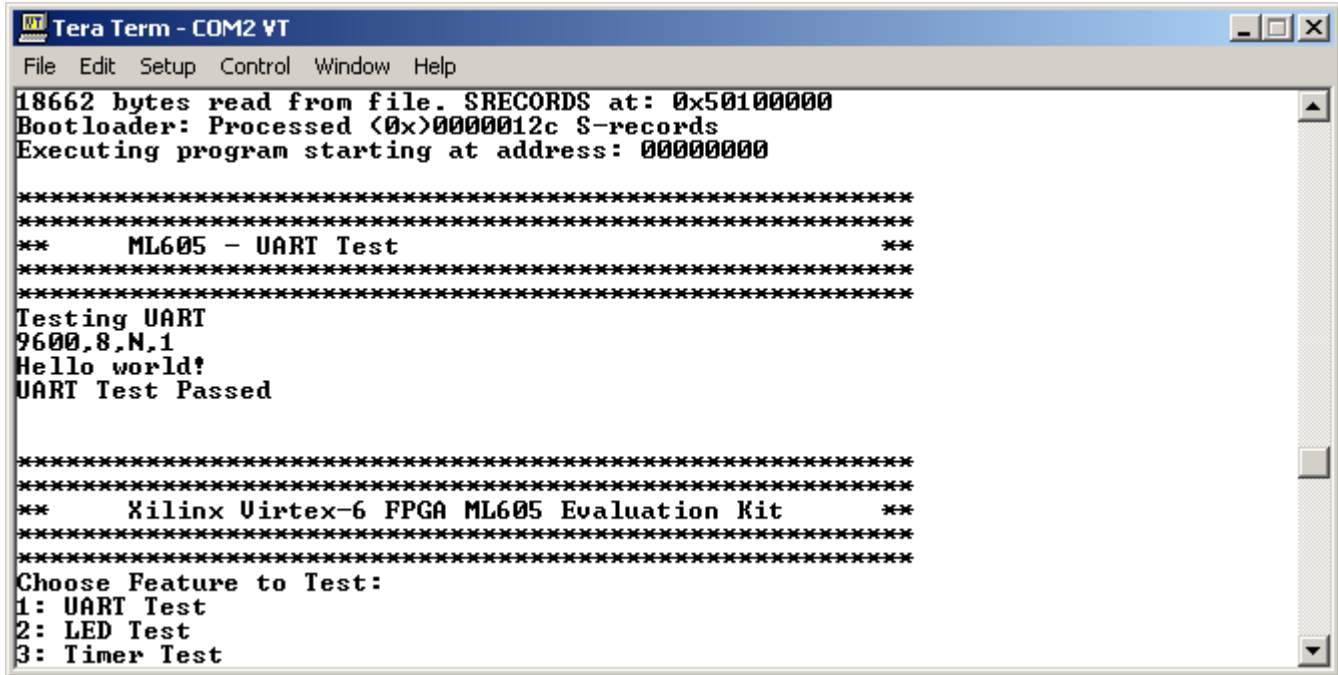

Figure 1-11: 1. UART Test

11. Type a **2** to start the LED test.

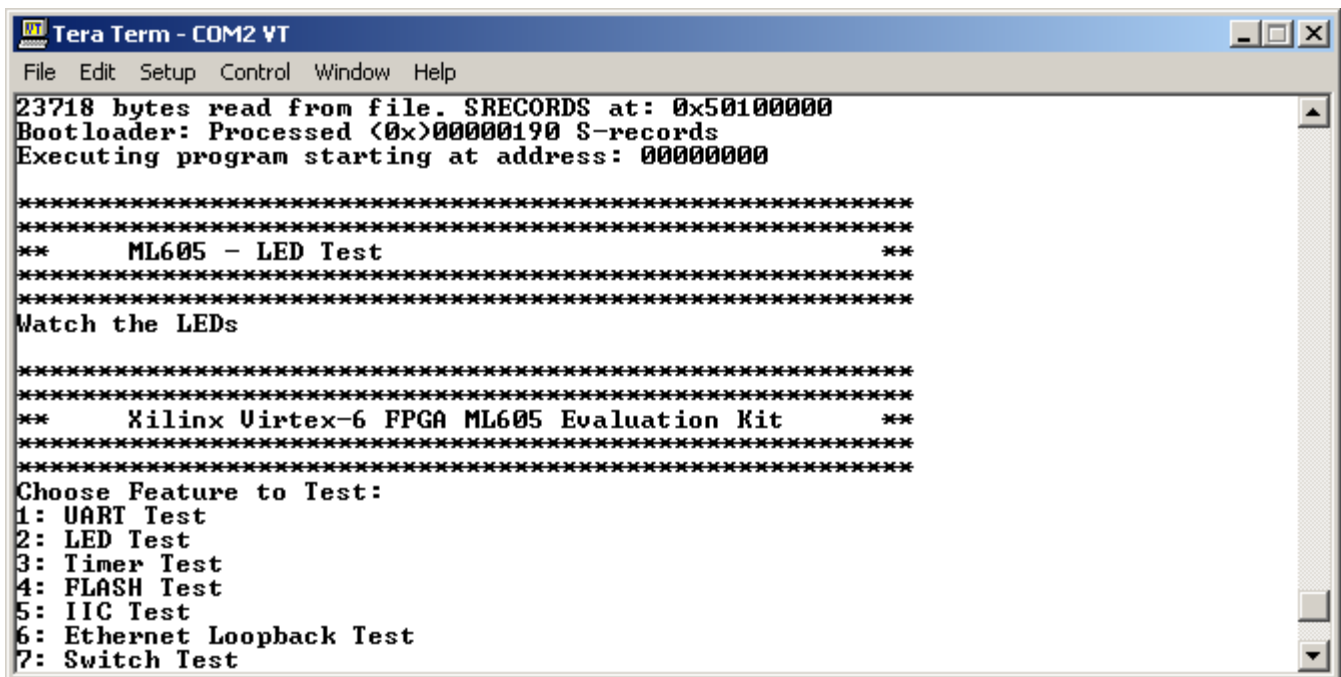
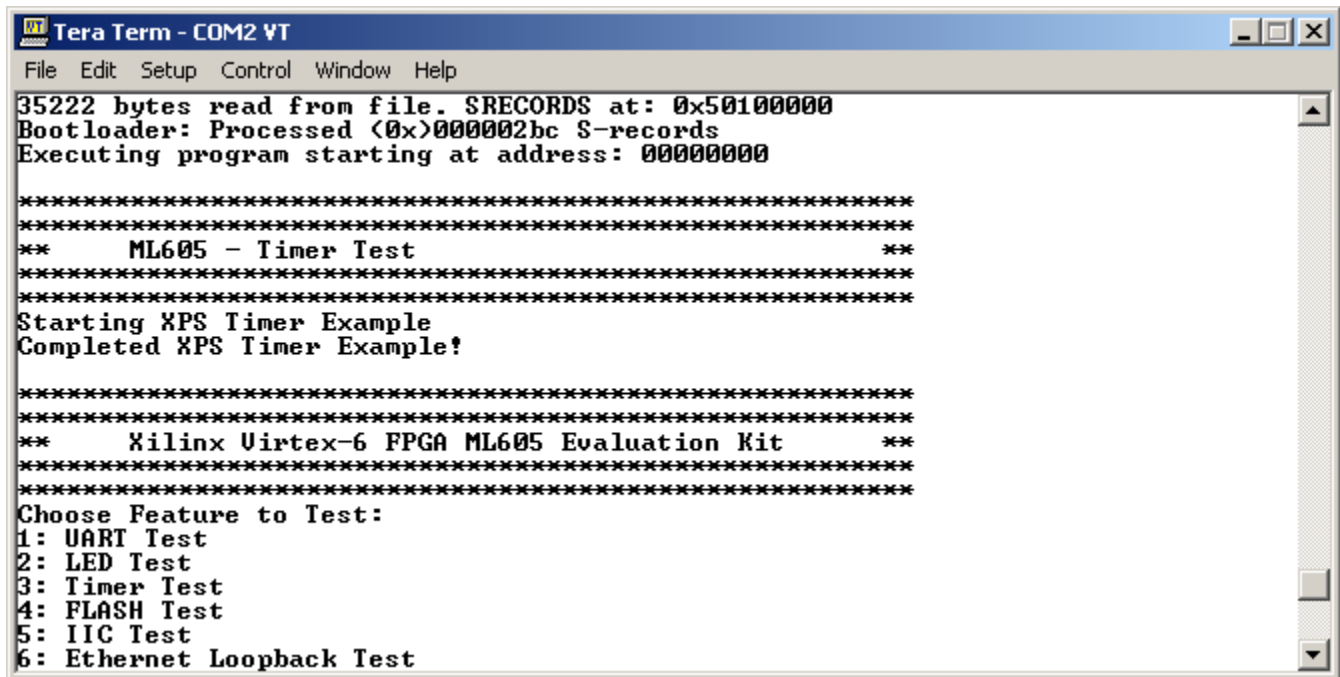

Figure 1-12: 2. LED Test

12. Type a **3** to start the Timer test.



```

Tera Term - COM2 VT
File Edit Setup Control Window Help
35222 bytes read from file. SRECORDS at: 0x50100000
Bootloader: Processed (0x)000002bc S-records
Executing program starting at address: 00000000

*****
**      ML605 - Timer Test      **
*****
Starting XPS Timer Example
Completed XPS Timer Example!

*****
**      Xilinx Uirtex-6 FPGA ML605 Evaluation Kit      **
*****
Choose Feature to Test:
1: UART Test
2: LED Test
3: Timer Test
4: FLASH Test
5: IIC Test
6: Ethernet Loopback Test

```

Figure 1-13: 3. Timer Test

13. Type a **4** to start the flash test.

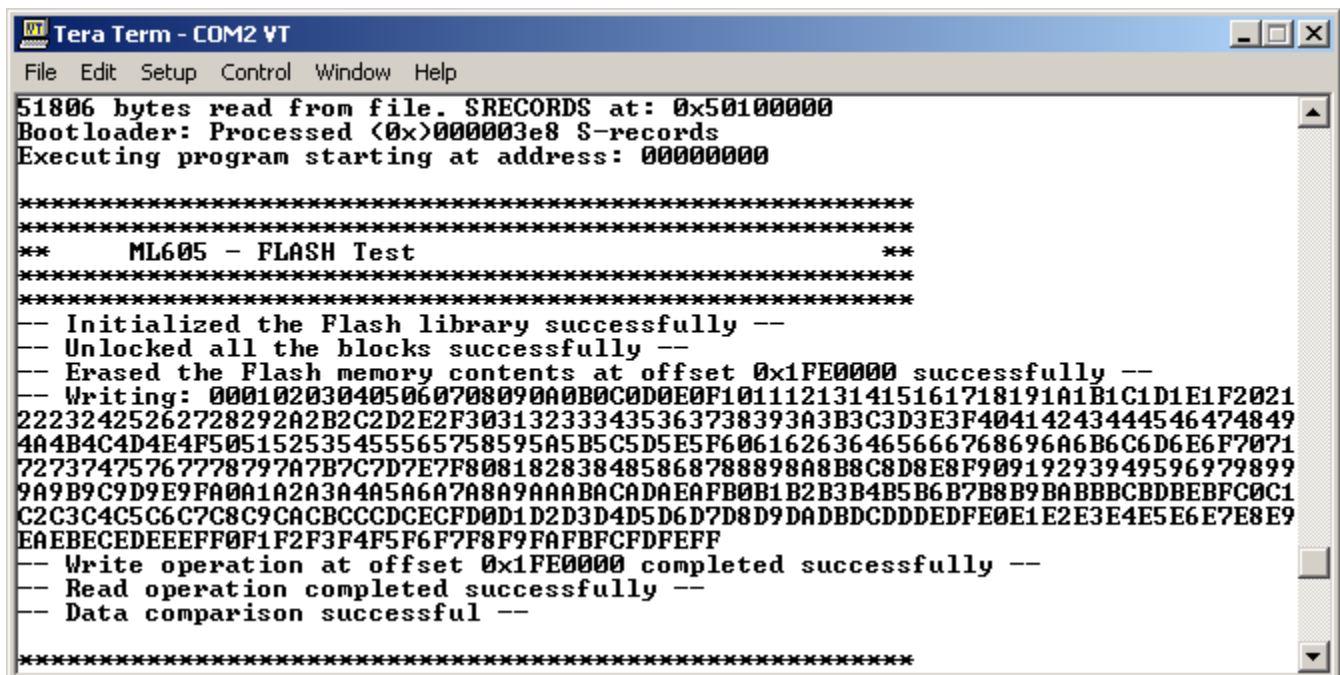

```

Tera Term - COM2 VT
File Edit Setup Control Window Help
51806 bytes read from file. SRECORDS at: 0x50100000
Bootloader: Processed (0x)000003e8 S-records
Executing program starting at address: 00000000

*****
**      ML605 - FLASH Test      **
*****
-- Initialized the Flash library successfully --
-- Unlocked all the blocks successfully --
-- Erased the Flash memory contents at offset 0x1FE0000 successfully --
-- Writing: 000102030405060708090A0B0C0D0E0F101112131415161718191A1B1C1D1E1F2021
22232425262728292A2B2C2D2E2F303132333435363738393A3B3C3D3E3F40414243444546474849
4A4B4C4D4E4F505152535455565758595A5B5C5D5E5F606162636465666768696A6B6C6D6E6F7071
72737475767778797A7B7C7D7E7F808182838485868788898A8B8C8D8E8F90919293949596979899
9A9B9C9D9E9FA0A1A2A3A4A5A6A7A8A9AAABACADAEAFB0B1B2B3B4B5B6B7B8B9BABBBBCDBEBFC0C1
C2C3C4C5C6C7C8C9CACBCCDCECFD0D1D2D3D4D5D6D7D8D9DADBDCDDDEDFE0E1E2E3E4E5E6E7E8E9
EAEBECEDEEEFF0F1F2F3F4F5F6F7F8F9FAFBFCFDFF
-- Write operation at offset 0x1FE0000 completed successfully --
-- Read operation completed successfully --
-- Data comparison successful --

*****

```

Figure 1-14: 4. Flash Test

14. Type a **5** to start the IIC EEPROM test.

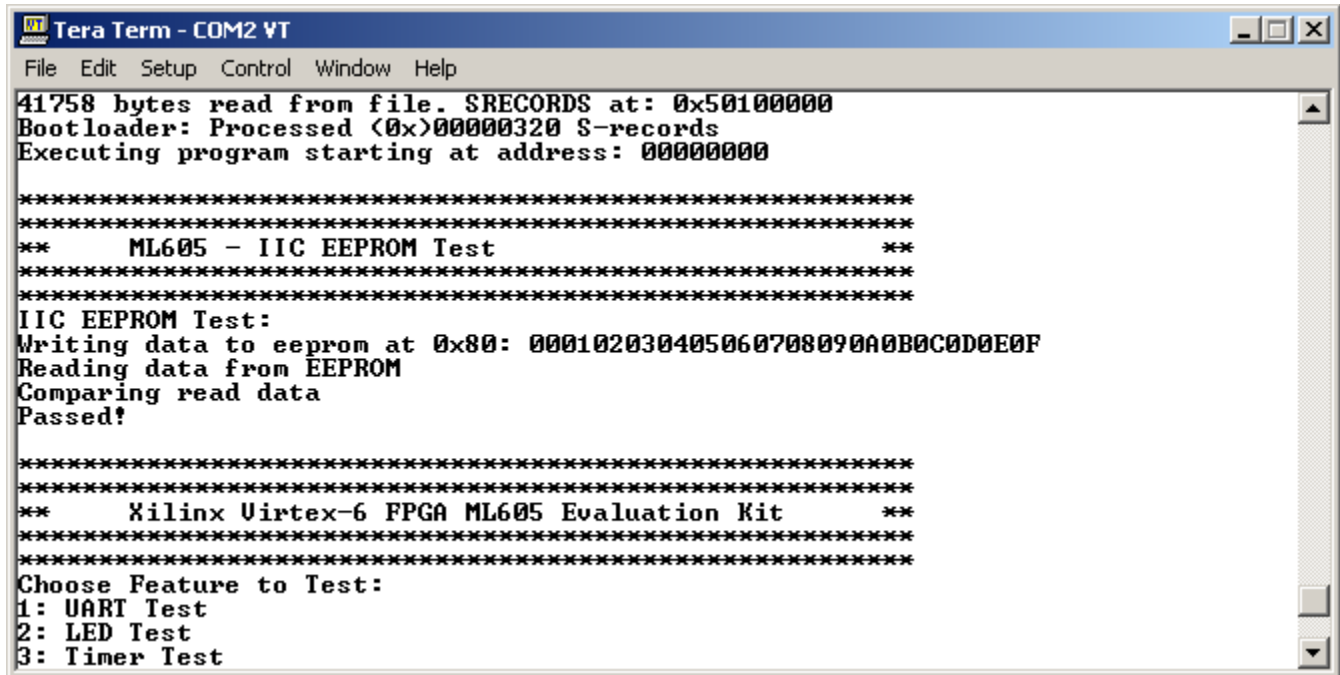

Figure 1-15: 5. IIC EEPROM Test

15. Type a **6** to start the Ethernet Loopback (Ternac) test. This takes approximately 10 seconds to complete.

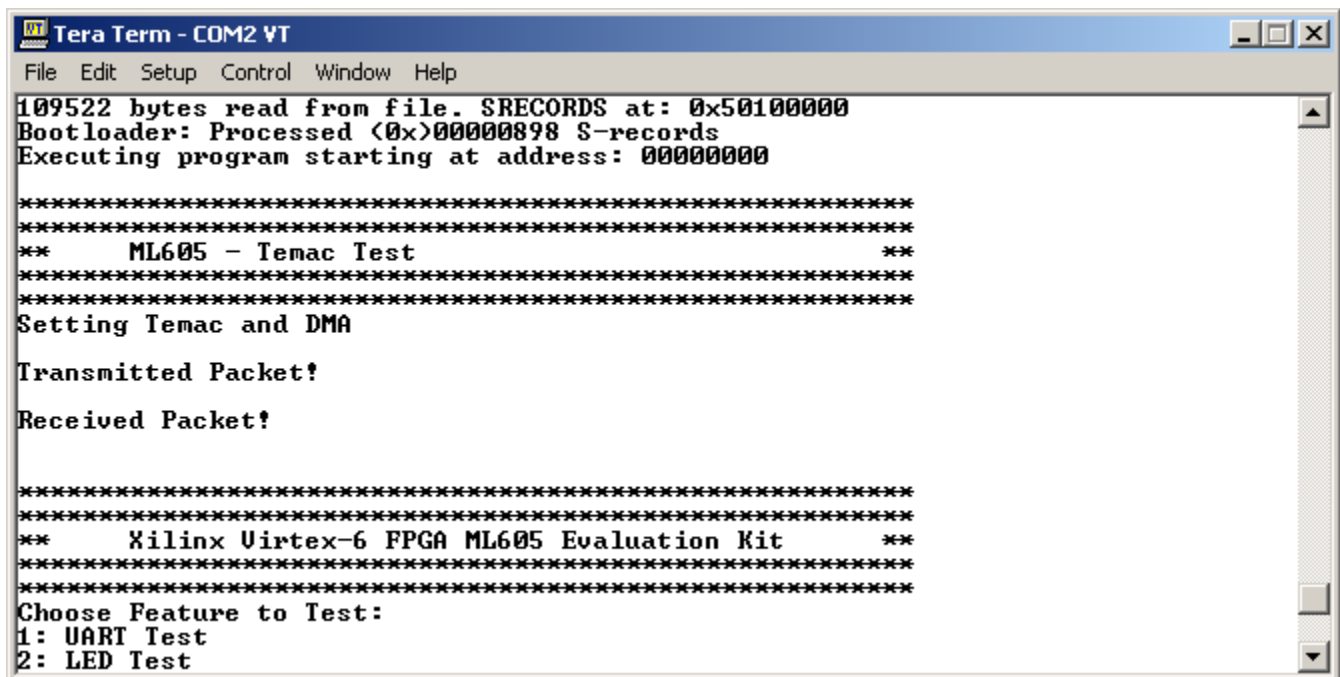
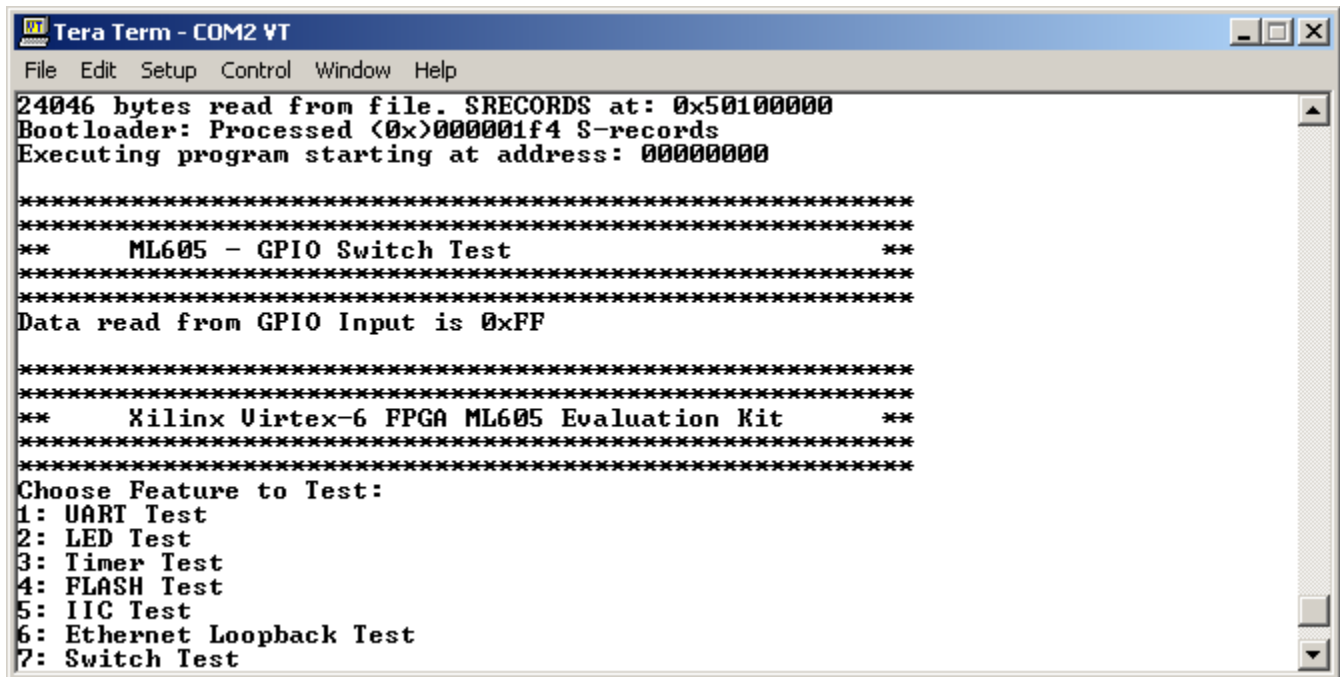

Figure 1-16: 6. Ternac Test

16. Type a **7** to start the GPIO Switch test.



```
Tera Term - COM2 VT
File Edit Setup Control Window Help
24046 bytes read from file. SRECORDS at: 0x50100000
Bootloader: Processed (0x)000001f4 S-records
Executing program starting at address: 00000000

*****
*****
**      ML605 - GPIO Switch Test      **
*****
*****
Data read from GPIO Input is 0xFF

*****
*****
**      Xilinx Virtex-6 FPGA ML605 Evaluation Kit      **
*****
*****
Choose Feature to Test:
1: UART Test
2: LED Test
3: Timer Test
4: FLASH Test
5: IIC Test
6: Ethernet Loopback Test
7: Switch Test
```

Figure 1-17: 7. GPIO Switch Test

17. Type an **8** to start the External Memory (Multi-Port Memory Controller, MPMC) test. This takes approximately 20 minutes to complete.

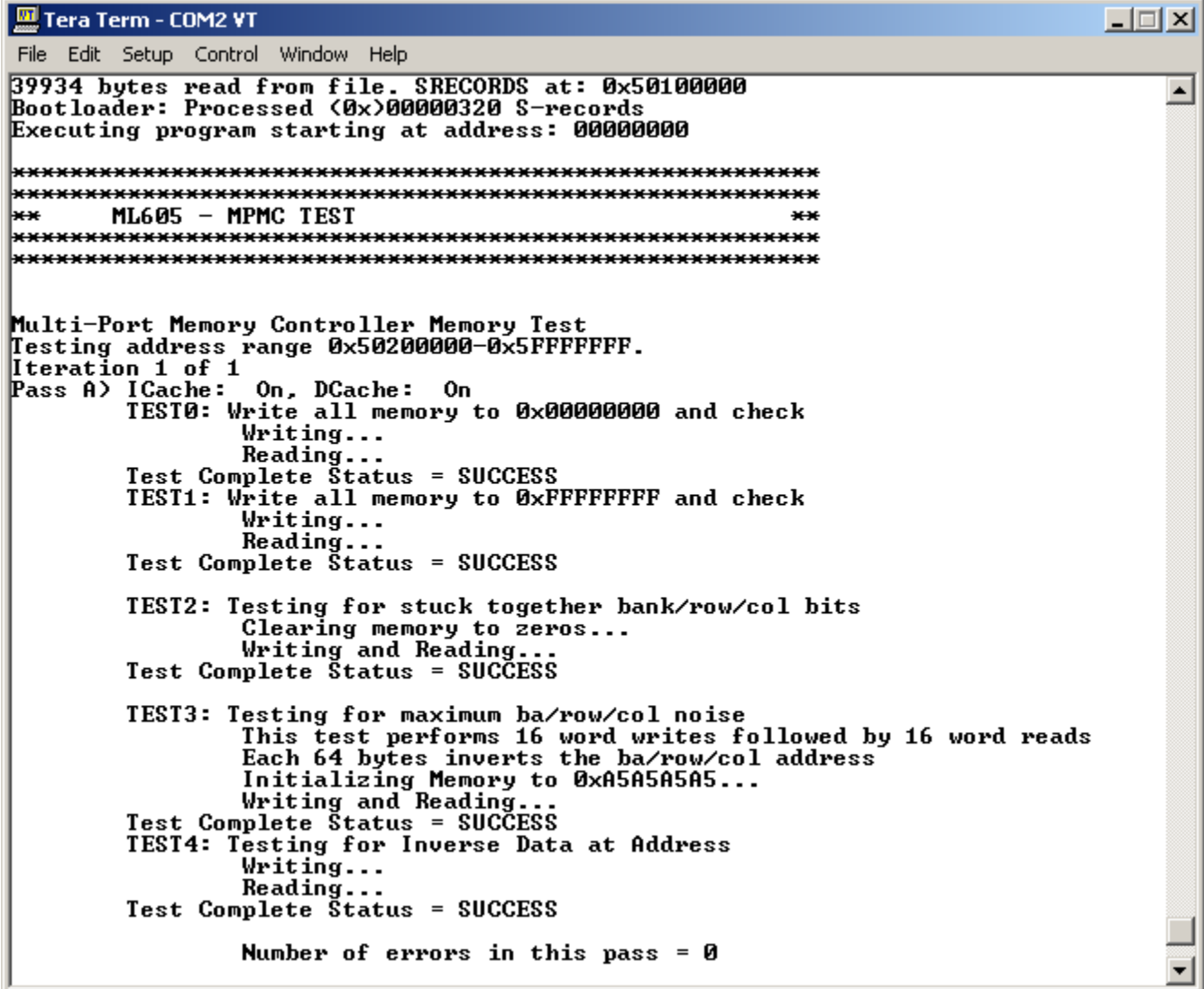

```
Tera Term - COM2 VT
File Edit Setup Control Window Help
39934 bytes read from file. SRECORDS at: 0x50100000
Bootloader: Processed (0x)00000320 S-records
Executing program starting at address: 00000000

*****
*****
**      ML605 - MPMC TEST      **
*****
*****

Multi-Port Memory Controller Memory Test
Testing address range 0x50200000-0x5FFFFFFF.
Iteration 1 of 1
Pass A) ICache: On, DCache: On
TEST0: Write all memory to 0x00000000 and check
      Writing...
      Reading...
      Test Complete Status = SUCCESS
TEST1: Write all memory to 0xFFFFFFFF and check
      Writing...
      Reading...
      Test Complete Status = SUCCESS

TEST2: Testing for stuck together bank/row/col bits
      Clearing memory to zeros...
      Writing and Reading...
      Test Complete Status = SUCCESS

TEST3: Testing for maximum ba/row/col noise
      This test performs 16 word writes followed by 16 word reads
      Each 64 bytes inverts the ba/row/col address
      Initializing Memory to 0xA5A5A5A5...
      Writing and Reading...
      Test Complete Status = SUCCESS
TEST4: Testing for Inverse Data at Address
      Writing...
      Reading...
      Test Complete Status = SUCCESS

      Number of errors in this pass = 0
```

Figure 1-18: 8. MPMC Test

Figure 1-19 shows the MPMC test status.

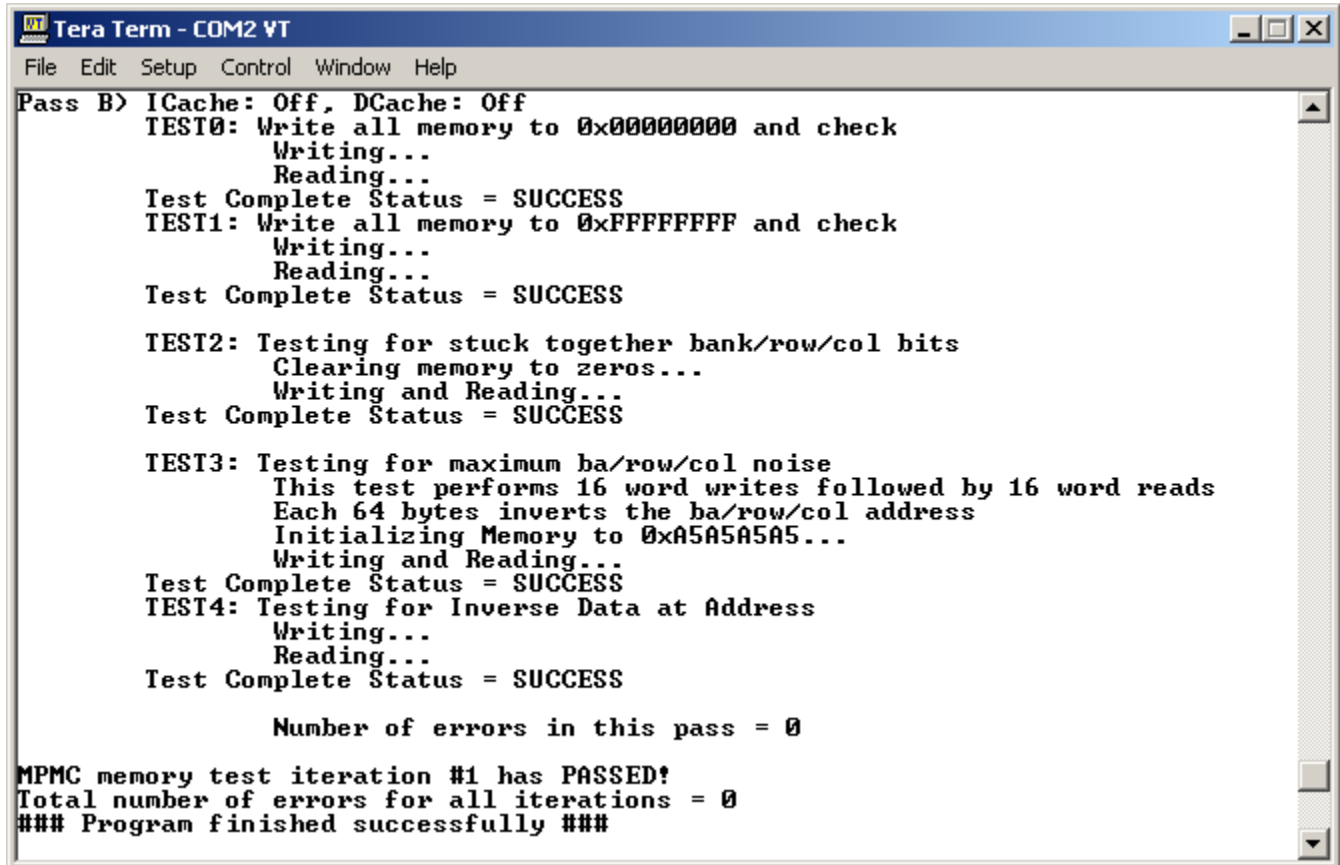

```
Pass B> ICache: Off, DCache: Off
TEST0: Write all memory to 0x00000000 and check
      Writing...
      Reading...
Test Complete Status = SUCCESS
TEST1: Write all memory to 0xFFFFFFFF and check
      Writing...
      Reading...
Test Complete Status = SUCCESS

TEST2: Testing for stuck together bank/row/col bits
      Clearing memory to zeros...
      Writing and Reading...
Test Complete Status = SUCCESS

TEST3: Testing for maximum ba/row/col noise
      This test performs 16 word writes followed by 16 word reads
      Each 64 bytes inverts the ba/row/col address
      Initializing Memory to 0xA5A5A5A5...
      Writing and Reading...
Test Complete Status = SUCCESS
TEST4: Testing for Inverse Data at Address
      Writing...
      Reading...
Test Complete Status = SUCCESS

      Number of errors in this pass = 0

MPMC memory test iteration #1 has PASSED!
Total number of errors for all iterations = 0
### Program finished successfully ###
```

Figure 1-19: MPMC Test Status

18. Type a **9** to start the System Monitor test.

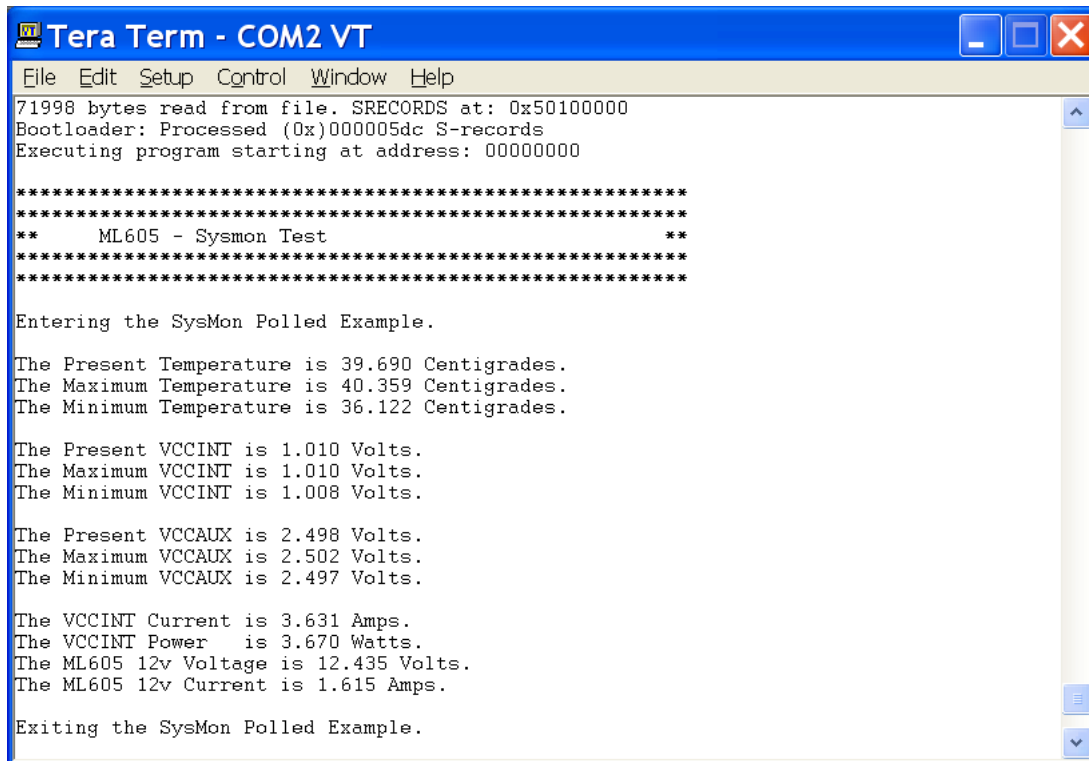

```
Tera Term - COM2 VT
File Edit Setup Control Window Help
71998 bytes read from file. SRECORDS at: 0x50100000
Bootloader: Processed (0x)000005dc S-records
Executing program starting at address: 00000000

*****
*****
**      ML605 - Sysmon Test      **
*****
*****

Entering the SysMon Polled Example.

The Present Temperature is 39.690 Centigrades.
The Maximum Temperature is 40.359 Centigrades.
The Minimum Temperature is 36.122 Centigrades.

The Present VCCINT is 1.010 Volts.
The Maximum VCCINT is 1.010 Volts.
The Minimum VCCINT is 1.008 Volts.

The Present VCCAUX is 2.498 Volts.
The Maximum VCCAUX is 2.502 Volts.
The Minimum VCCAUX is 2.497 Volts.

The VCCINT Current is 3.631 Amps.
The VCCINT Power is 3.670 Watts.
The ML605 12v Voltage is 12.435 Volts.
The ML605 12v Current is 1.615 Amps.

Exiting the SysMon Polled Example.
```

Figure 1-20: 9. System Monitor Test

19. Type an **A** to test the North, South, East, West, and Center pushbuttons (as shown in Figure 1-21).

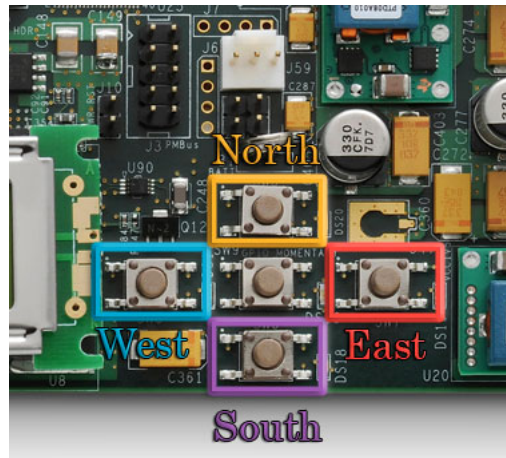

Figure 1-21: ML605 North, South, East, West, and Center Pushbuttons

Figure 1-22 shows the test menu.

```

COM2:9600baud - Tera Term VT
File Edit Setup Control Window Resize Help
18870 bytes read from file. SRECORDS at: 0x50100000
Bootloader: Processed (0x)0000012c S-records
Executing program starting at address: 00000000

*****
**      ML605 - Button Test      **
*****
Press West Button & see if LED 0 glows
Press South Button & see if LED 1 glows
Press East Button & see if LED 2 glows
Press North Button & see if LED 3 glows
Press Center Button & see if all the 4 LEDs glow

*****
**      Xilinx Virtex-6 FPGA ML605 Evaluation Kit      **
*****

```

Figure 1-22: Pushbutton Test

20. Type a **B** to start the LCD test.

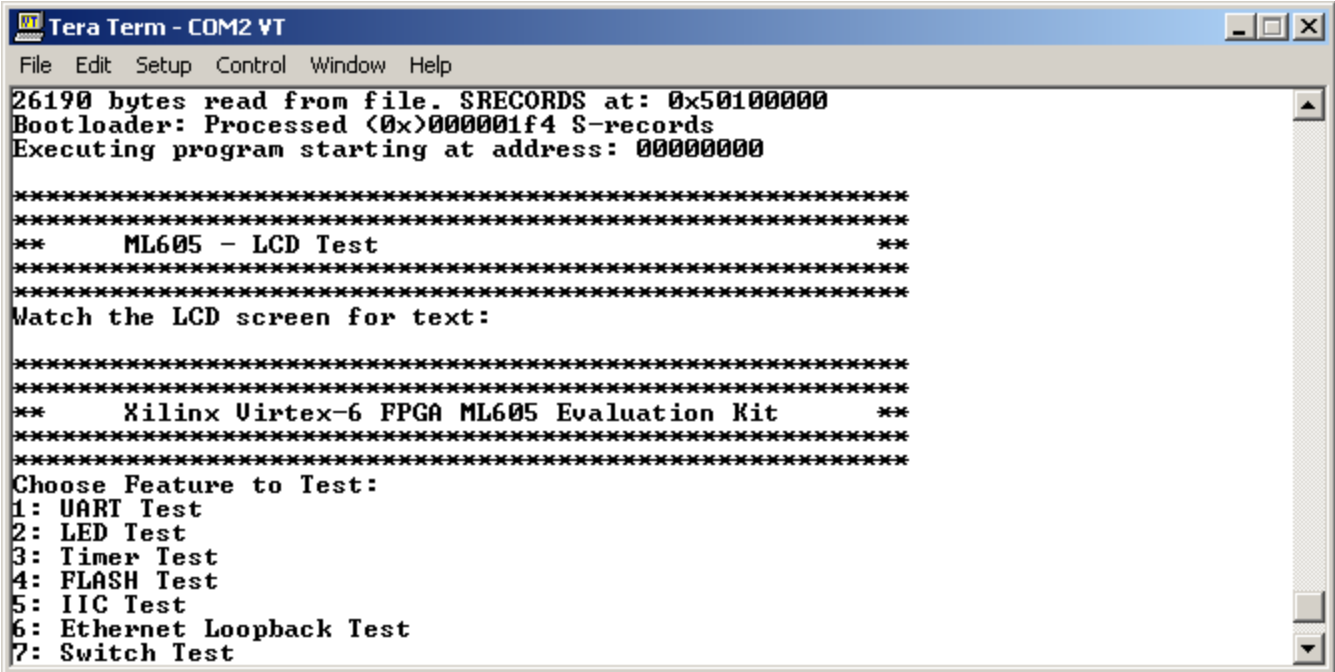

```
Tera Term - COM2 VT
File Edit Setup Control Window Help
26190 bytes read from file. SRECORDS at: 0x50100000
Bootloader: Processed (0x)000001f4 S-records
Executing program starting at address: 00000000

*****
*****
**      ML605 - LCD Test      **
*****
*****
Match the LCD screen for text:

*****
*****
**      Xilinx Uirtex-6 FPGA ML605 Evaluation Kit      **
*****
*****
Choose Feature to Test:
1: UART Test
2: LED Test
3: Timer Test
4: FLASH Test
5: IIC Test
6: Ethernet Loopback Test
7: Switch Test
```

Figure 1-23: LCD Test

21. Type a **C** to start the System ACE CF test.

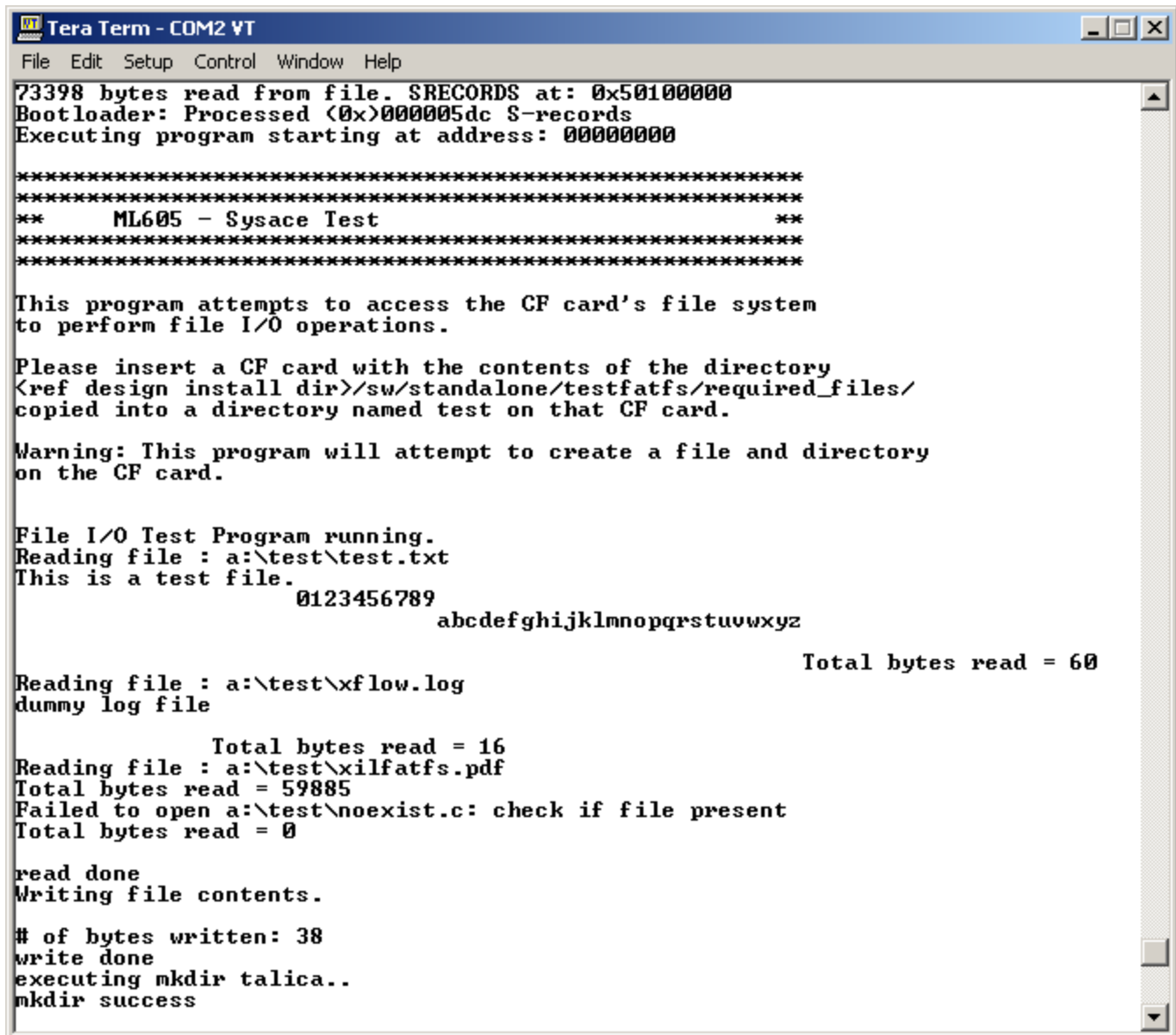

```

Tera Term - COM2 VT
File Edit Setup Control Window Help
73398 bytes read from file. SRECORDS at: 0x50100000
Bootloader: Processed (0x)000005dc S-records
Executing program starting at address: 00000000

*****
*****
**      ML605 - Sysace Test      **
*****
*****

This program attempts to access the CF card's file system
to perform file I/O operations.

Please insert a CF card with the contents of the directory
<ref design install dir>/sw/standalone/testfatfs/required_files/
copied into a directory named test on that CF card.

Warning: This program will attempt to create a file and directory
on the CF card.

File I/O Test Program running.
Reading file : a:\test\test.txt
This is a test file.
                0123456789
                  abcdefghijklmnopqrstuvwxyz

                                                    Total bytes read = 60

Reading file : a:\test\xflow.log
dummy log file

                Total bytes read = 16
Reading file : a:\test\xilfatfs.pdf
Total bytes read = 59885
Failed to open a:\test\noexist.c: check if file present
Total bytes read = 0

read done
Writing file contents.

# of bytes written: 38
write done
executing mkdir talica..
mkdir success

```

Figure 1-24: System ACE CF Test

22. Connect a DVI monitor to the ML605 board using the connector shown in [Figure 1-25](#). The DVI/VGA adapter provided in the ML605 Evaluation Kit can be used to connect a VGA monitor.

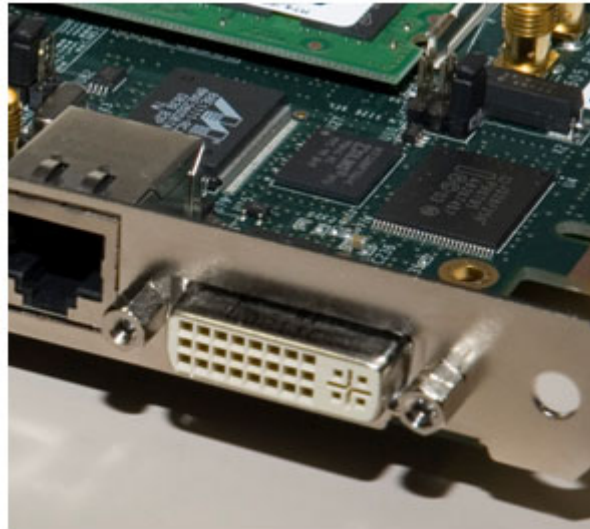

Figure 1-25: ML605 DVI Connector

23. Type a **D** to start the DVI/VGA (TFT) test. The test patterns indicated in [Figure 1-26](#) appear on the monitor.

```
Tera Term - COM2 VT
File Edit Setup Control Window Help
43982 bytes read from file. SRECORDS at: 0x50100000
Bootloader: Processed (0x)00000384 S-records
Executing program starting at address: 00000000
*****
**      ML605 - TFT Test      **
*****
Display color
Painting Screen RED
Painting Screen GREEN
Painting Screen BLUE
Writing Color Bar Pattern
TFT test completed!
You should see vertical color and grayscale bars
across your VGA Output Monitor
*****
**      Xilinx Uirtex-6 FPGA ML605 Evaluation Kit      **
*****
```

Figure 1-26: TFT Test

Getting Started with PCI Express PIO Demonstration

The LogiCORE™ IP Virtex-6 Integrated Block for PCI Express® core is a high-bandwidth, scalable, and reliable serial interconnect building block for use with Virtex-6 FPGA devices. The Integrated Block for PCI Express solution supports 1-lane, 2-lane, 4-lane, and 8-lane Endpoint and Root Port configurations at up to Gen2 speed, all of which are compliant with the *PCI Express Base Specification, v2.0*.

For information about the internal architecture of the Virtex-6 FPGA Integrated Block, see the *LogiCORE™ IP Virtex-6 FPGA Integrated Block User Guide for PCI Express*. [Ref 18]

Figure 1-27 illustrates the interfaces to the core.

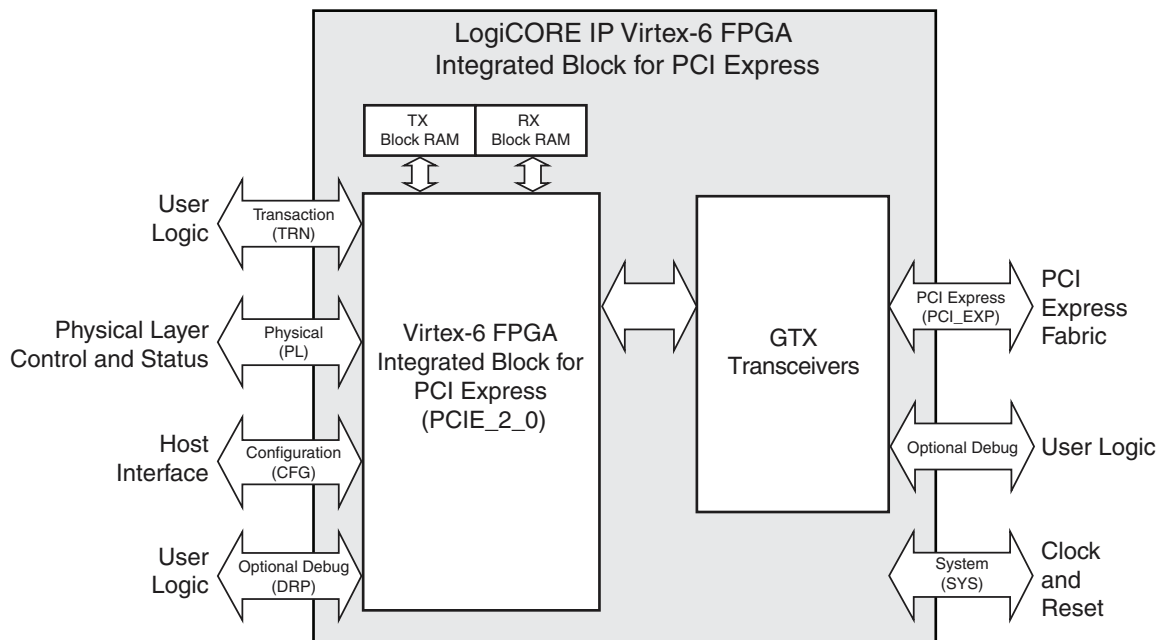

UG533_11_101609

Figure 1-27: Interfaces to the Core

The ML605 x8 PCI Express Gen 1 Programmed Input Output (PIO) design consists of a simple example that can accept read and write transactions and respond to requests. PIO transactions are generally used by a PCI Express system host CPU to access Memory Mapped Input Output (MMIO) and Configuration Mapped Input Output (CMIO) locations in the PCI Express fabric. Endpoints for PCI Express accept Memory and IO Write transactions and respond to Memory and IO Read transactions with Completion with Data transactions.

The ML605 PIO example design is included with the Endpoint for PCIe generated by the CORE Generator, which allows users to easily bring up their system board with a known established working design to verify the link and functionality of the board.

The step-by-step procedure for creating the PIO design by Xilinx CORE Generator™ software is illustrated by the *ML605 PCIe x8 Gen1 Design Creation* tutorial [Ref 23]. See <http://www.xilinx.com/products/devkits/EK-V6-ML605-G.htm>.

System Requirements, Installation, and Setup

Software Requirement

PciTree is a graphical Windows tool that can be used for checking the presence of PCI devices in PCIbus.

Software Installation and Setup

1. Download the free PciTree tool (Figure 1-28) from <http://www.pcitree.de/download.html>
2. Unzip PCITree.zip to your folder of choice
3. Click on PCITree.exe and proceed with the installation
4. Copy HLP.SYS to C:\WINDOWS\system32\drivers directory
5. Verify the installation

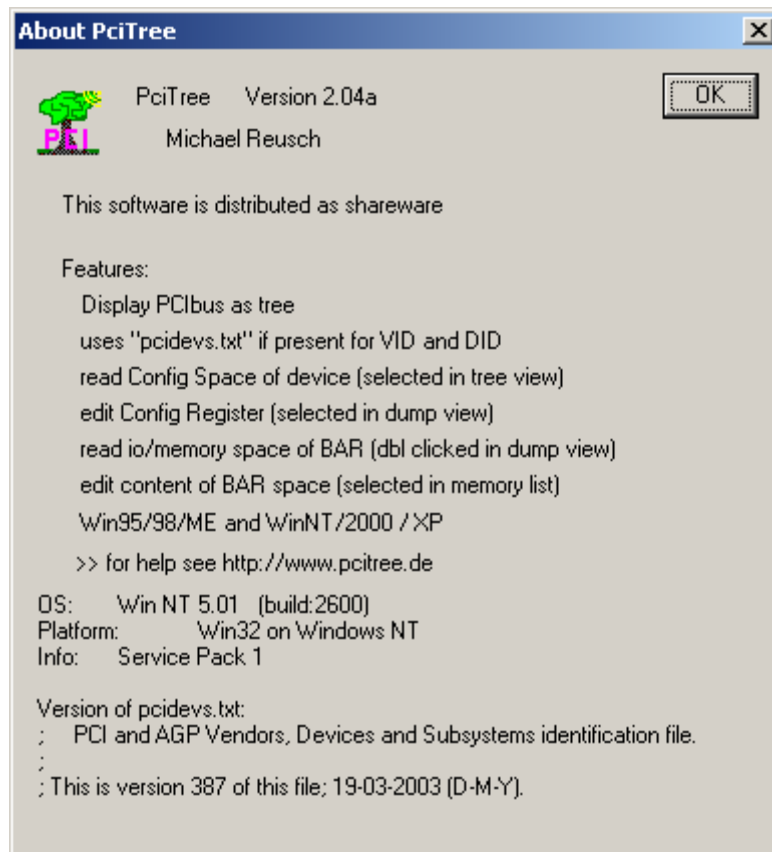

Figure 1-28: About the PciTree Tool

Hardware Requirement

- PC with Gen 1 x8 or x16 PCI Express slot fully dedicated for add-on end-point PCIe card (the slot should not be dedicated to graphic cards only)
- ML605 board

Hardware Installation and Setup

All jumpers on the ML605 should remain set to the factory default. As viewed from left-to-right in [Figure 1-29](#), S2 is set to 011001. This will configure the FPGA from the Platform Flash XL device using Slave SelectMAP and the onboard external oscillator for CCLK. J42 should also have a shunt on pins 5 and 6 for x8 PCI Express configuration.

6. Ensure Configuration Mode Switch S2 is set to 011001 (position 6 to position 1)
7. Insert your ML605 board into a PCIe x8 slot (x16 as shown in [Figure 1-29](#)).
8. Connect your PC power to J25 and turn on the power switch.

Caution! Do not use the PCIe power connector from the PC power supply. Use only the 4-pin ATX connector.

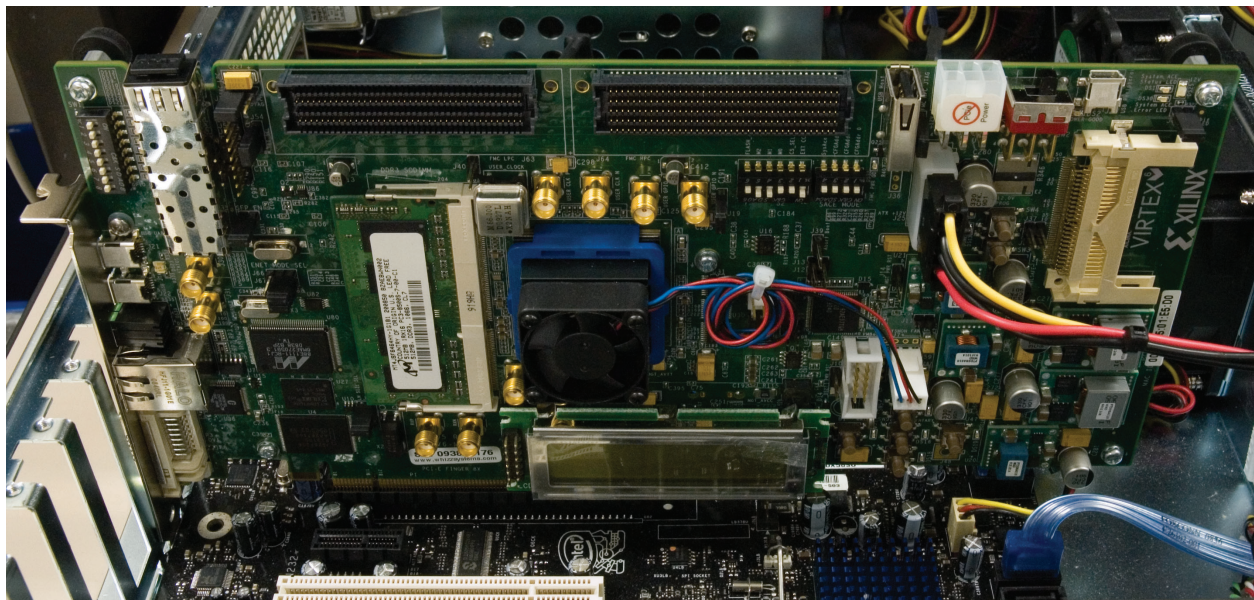

UG533_c1_29_060110

Figure 1-29: Board Insertion Location

Running the PCI Express PIO Demonstration

9. Power on your PC and wait for your ML605 board to power up consequently.
10. The x8 PCI Express PIO design is pre-loaded on the ML605 board's Platform Flash XL. Upon the board's power up and successful configuration of the onboard LX240T FPGA, the DONE LED (DS13) should illuminate.
11. Launch the PciTree tool and verify the menu shown in [Figure 1-30](#).

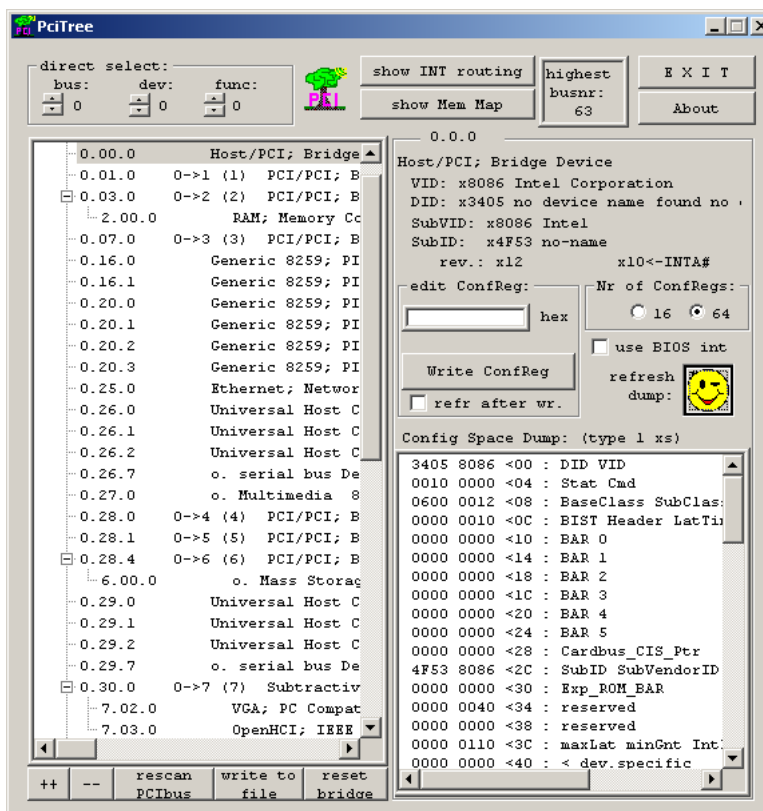

Figure 1-30: Launch the PciTree Tool

Configuration Registers Test

- Set the number of configuration registers to 64 (as shown in Figure 1-31) and click on the **refresh dump** button.

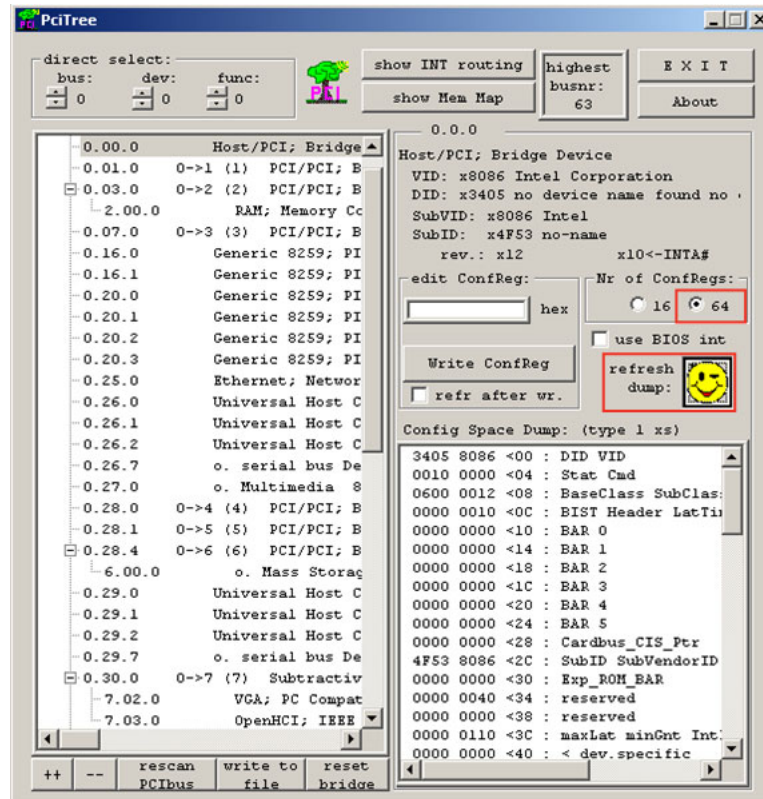

Figure 1-31: Set Configuration Registers

13. Locate the Xilinx device as shown in figure [Figure 1-32](#).
- ◆ Xilinx PCI vendor ID is 0x10EE
 - ◆ Device ID of the x8 Gen1 configuration is 0x6018

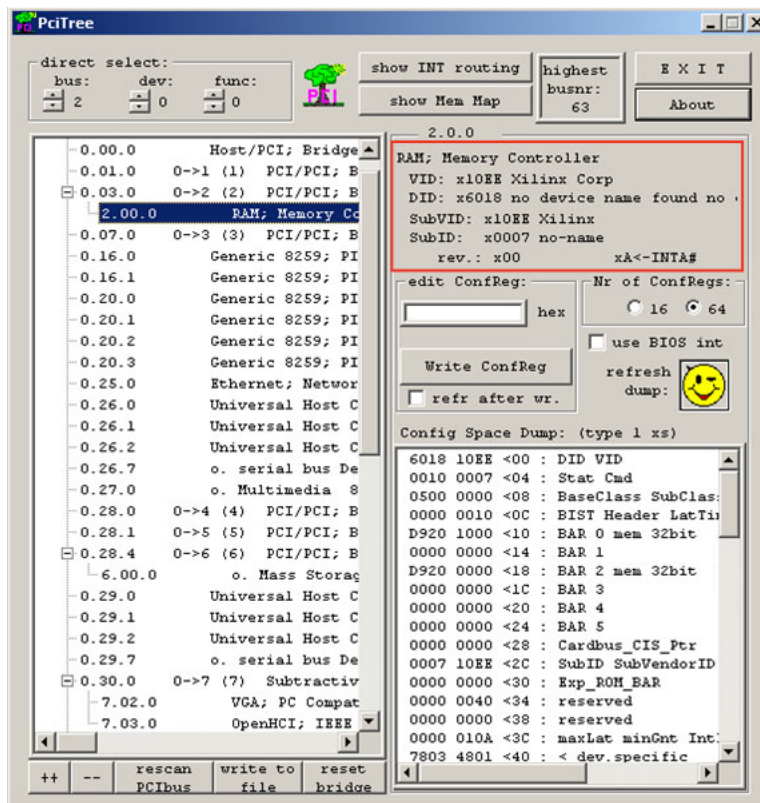

Figure 1-32: Locate the Xilinx Device

14. Navigate to the linked list in the configuration space (as shown in Figure 1-33) to locate the PCIe capabilities structure.
15. With the Xilinx device selected, select register 0x40.
 - ◆ Register 0x40 points to the next structure
 - ◆ 0x48 is the address of the next structure

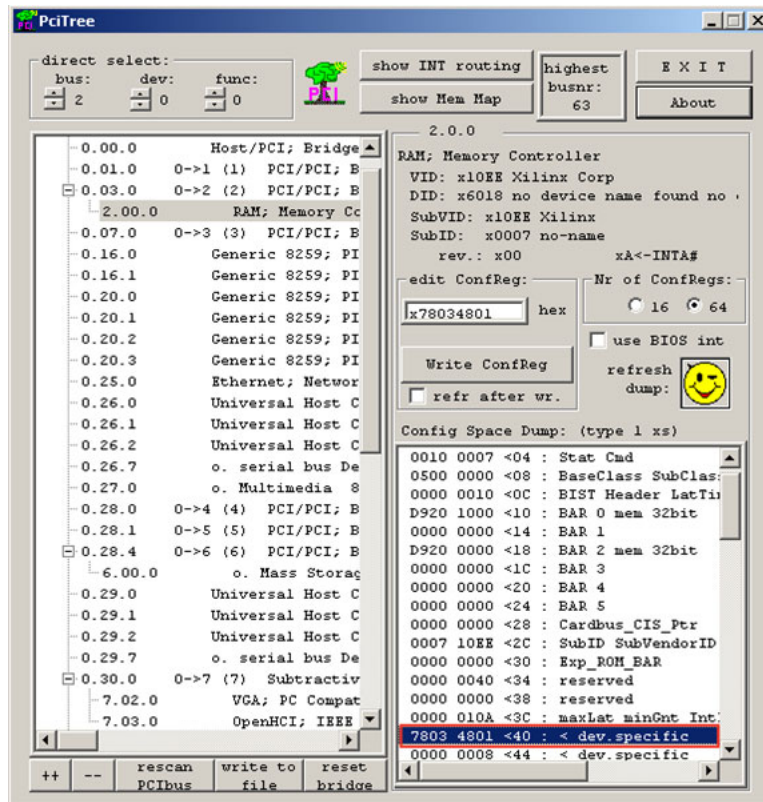

Figure 1-33: Locate the PCIe Capabilities Structure

16. Select register 0x48 (as shown in Figure 1-34).
 - ◆ Register 0x48 points to the next structure
 - ◆ 0x60 is the address of the next structure, indicating the data at this offset is the PCIe Capabilities Structure.

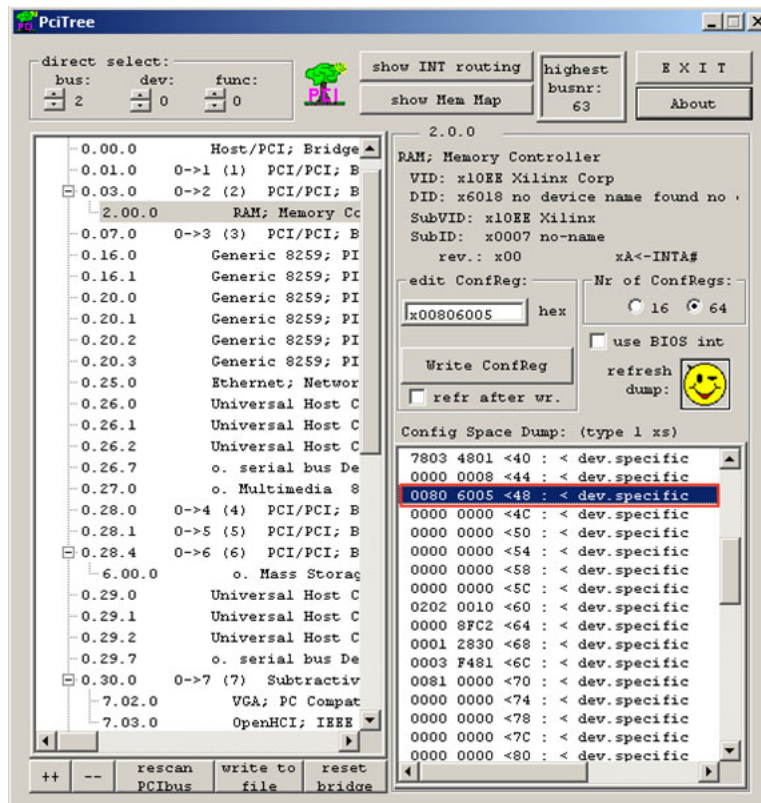

Figure 1-34: Select Register 0x48

17. Select register 0x60 (as shown in Figure 1-35).
 - ◆ 0x60 is a type 0x10

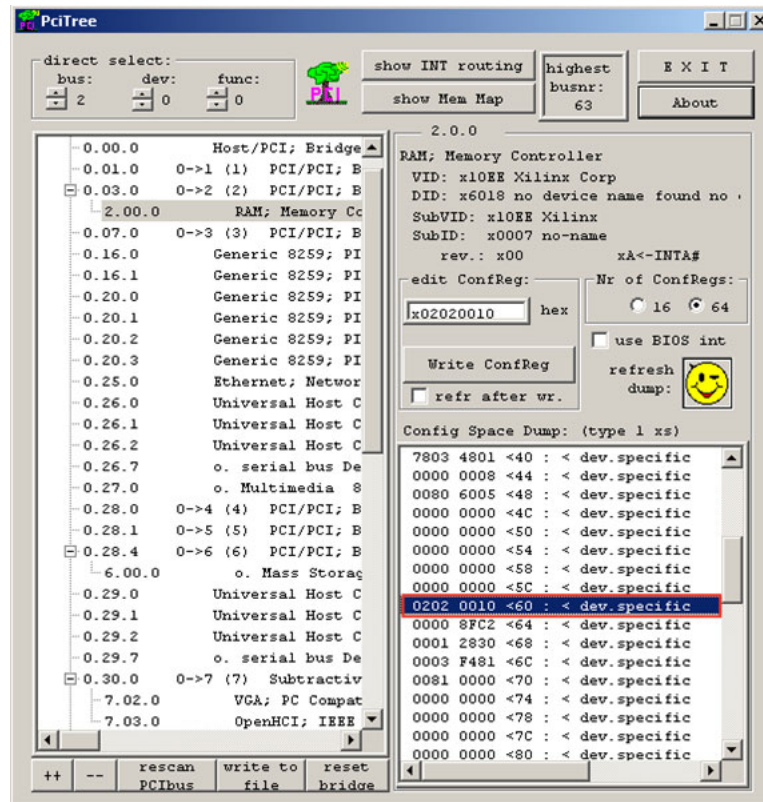

Figure 1-35: Select Register “0x60”

18. Select register 0x6C, Link Capabilities Register (Figure 1-36).
 - ◆ Indicates the maximum number of lanes and speed supported
 - ◆ The value 0x81 shows this is an x8 Gen1 capable device

The Link Status Register (0x70) shows the current link status

 - ◆ This design is trained to Gen1 x8 as indicated by 0x81

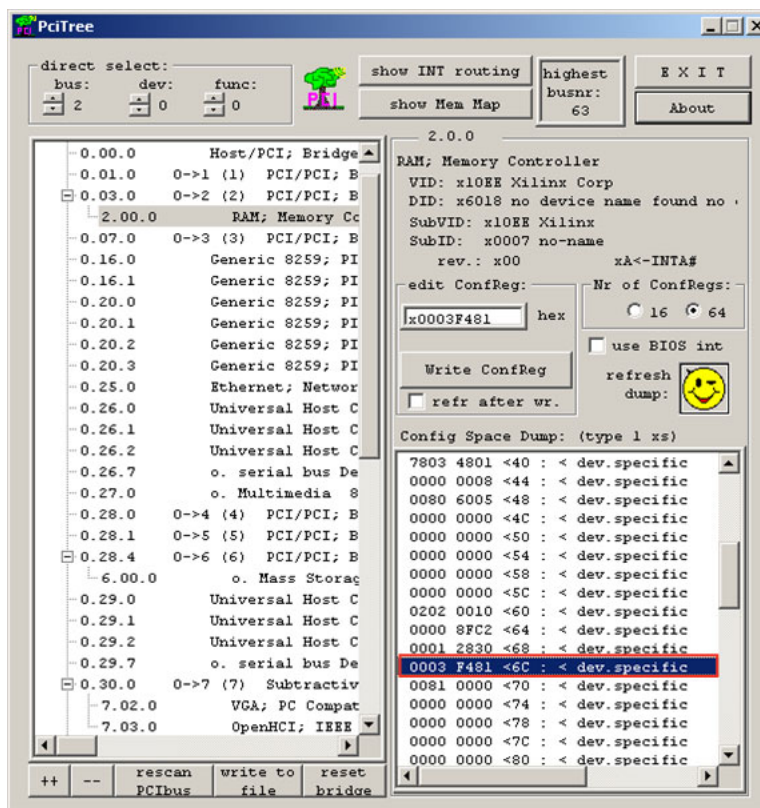

Figure 1-36: Select Register 0x6C

Base Address Register (BAR) Test

19. Double-click on BAR 0 (as shown in [Figure 1-37](#)).
 - ◆ BAR 0 address is machine dependent

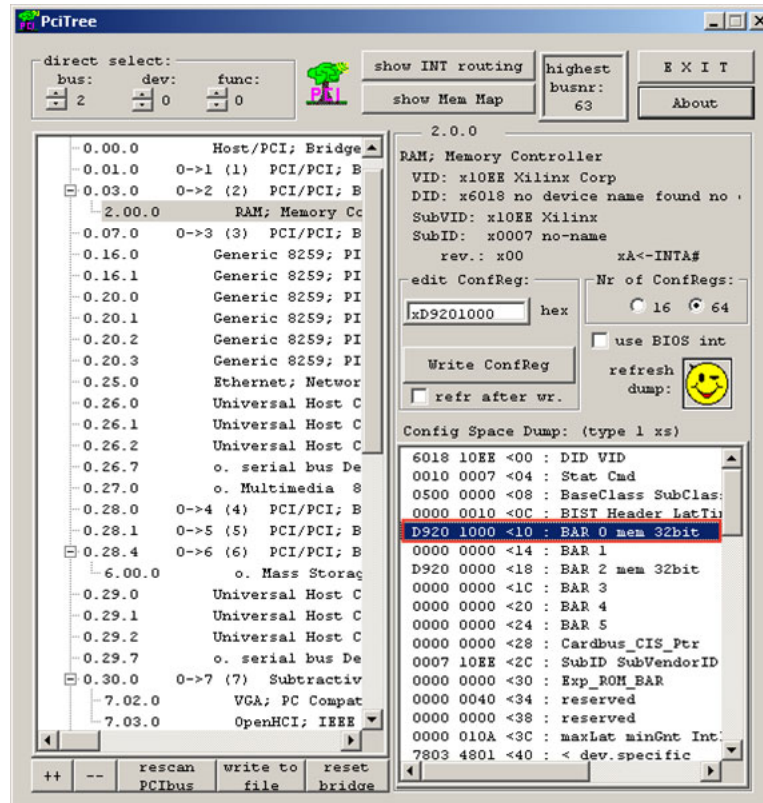

Figure 1-37: Double-Click on BAR 0

20. Click Yes on the dialog box (as shown in [Figure 1-38](#)).

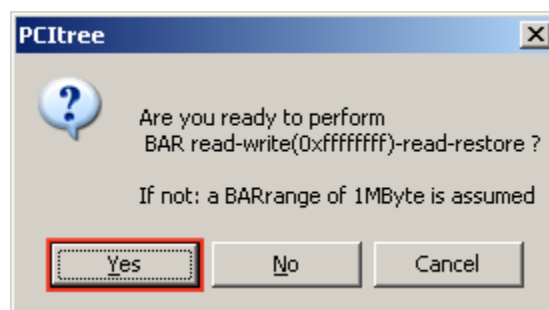

Figure 1-38: Click Yes

21. Select auto read memory (as shown in Figure 1-39).

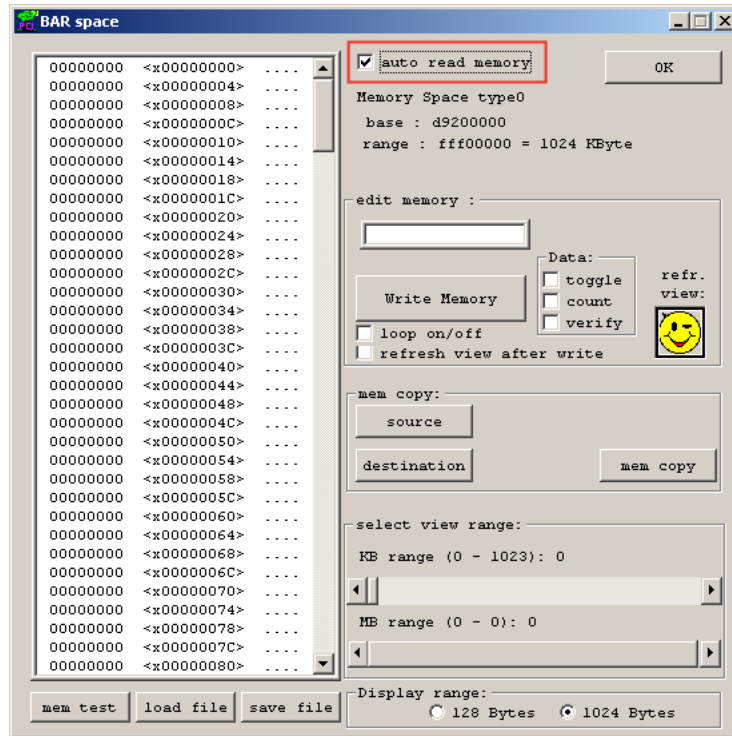

Figure 1-39: Select Auto Read Memory

22. Click on the first memory location by holding <Shift-End> keys. This will select 1024 bytes as shown in [Figure 1-40](#).

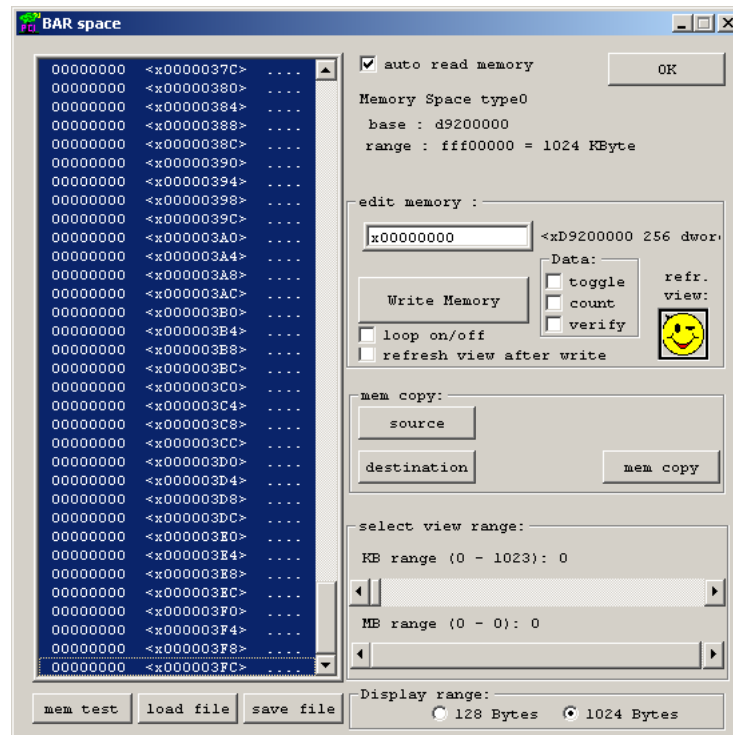

Figure 1-40: Select 1024 Bytes

23. Write to memory by selecting the count box and Write Memory button (as shown in Figure 1-41).
24. Verify the result (counting up to FF) by selecting the **refr. view:** button.

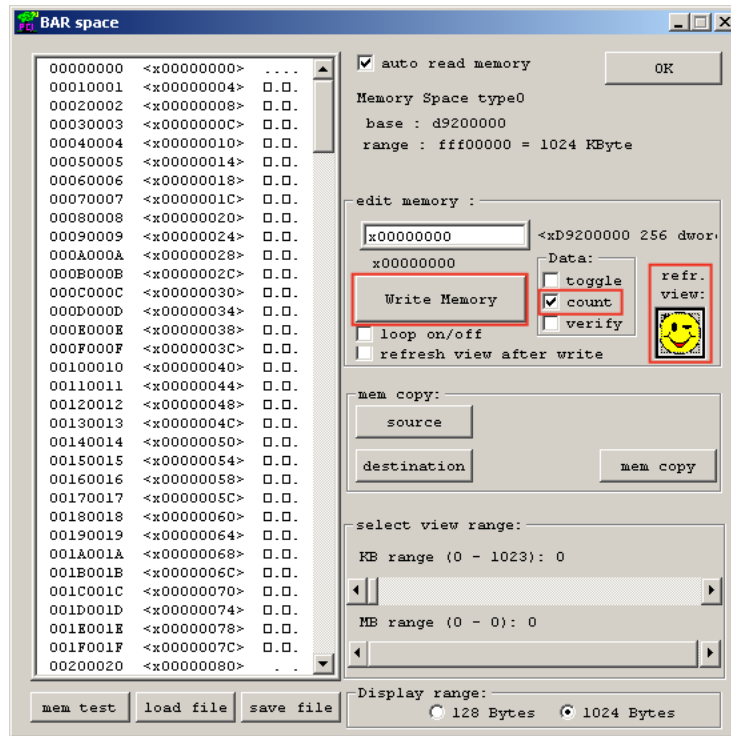

Figure 1-41: Select to Write Memory

25. Restore the memory by deselecting the count box and clicking the Write Memory button (as shown in [Figure 1-42](#)).
26. Review the result by clicking on the **refr. view:** button.

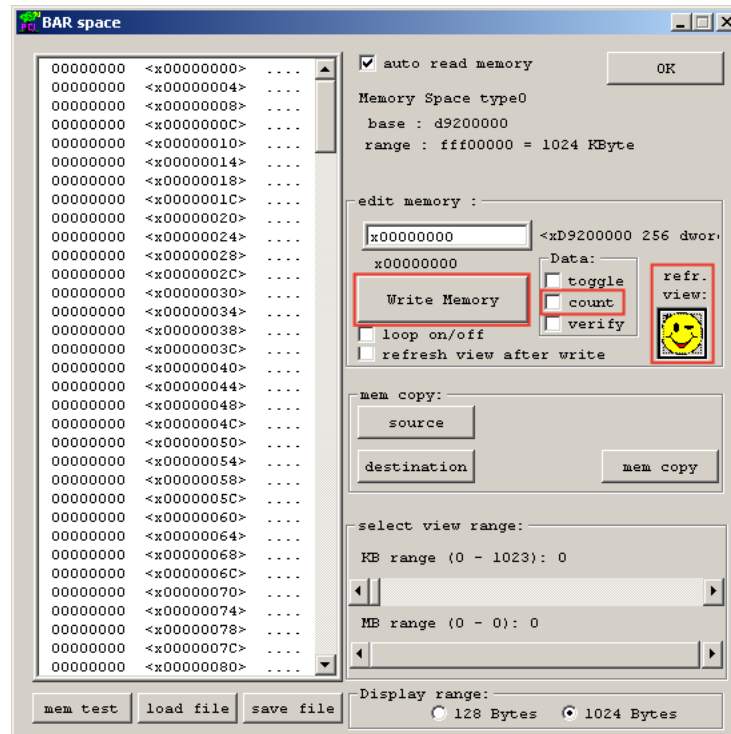
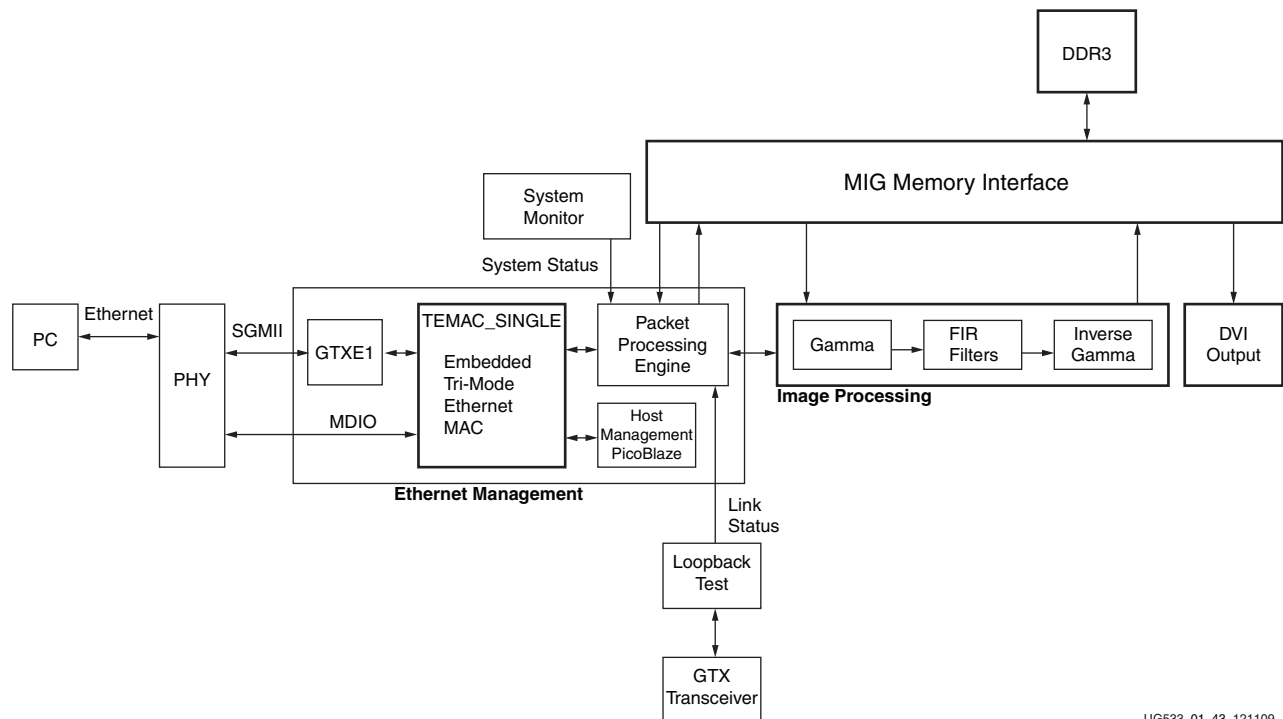

Figure 1-42: Restore Memory

Getting Started with the Base Reference Design

The Base Reference Design targeting the ML605 evaluation board, will filter images that are transferred via Ethernet between the evaluation board and a PC. The images are stored in DDR3 SDRAM available on the evaluation board. The stored image is continuously read from SDRAM and filtered by the LX240T FPGA. The resulting image is continuously stored back in the DDR3 SDRAM. This filtered image is then retrieved by the Base Reference Design Interface Software and displayed on a PC.

Figure 1-43 shows a block diagram of the base reference design that has been implemented in the Virtex-6 LX240T FPGA. The reference design includes common functions for Ethernet SGMII communication, external memory interface, UART, and control.



UG533_01_43_121109

Figure 1-43: Base Reference Design Block Diagram

A DDR3 Memory Controller Block is used to store both the unfiltered and filtered images in the DDR3 SDRAM. These images are sent from a PC via a series of Ethernet packets. This memory controller is continuously reading, filtering, and storing images back into this memory. The PC also periodically retrieves the filtered images via Ethernet for display. The Ethernet Management section includes an on-chip hard coded MAC and a Packet Processing Engine. This section provides a way to control various aspects of the demo, transfer images between the demo board and a PC, and receive status from the demo. A simple MDIO controller is implemented using a Xilinx PicoBlaze™ processor. The purpose of this controller is to determine presence of an Ethernet link as well as its operating speed.

The Image Processing structure consists of a 5x5 pixel 2D FIR filter.

Setting up the Hardware for the Base Reference Design

1. Power-off the ML605
2. Connect one end of the provided Ethernet cable to the RJ45 connector P2 on the ML605 and the other end to the Ethernet port on your PC. This connection will be used for communication between the ML605 board and your PC.
3. Set the Ethernet Jumpers for SGMII mode
 - ◆ J66: Shunt over pins 2 and 3
 - ◆ J67: Shunt over pins 2 and 3
 - ◆ J68: No shunt
4. Insert the provided CompactFlash (CF) card into the ML605 CF reader (U73)
5. Set the SACE MODE switch S1 to 1011 (Position 4 to Position 1). This will configure the FPGA from the ACE file stored at configuration address 3 on the CF card
6. Do not change any other factory default settings
7. Power-on the ML605

Installing Base Reference Design Application GUI

The Base Reference Design includes an application GUI that must be installed before you will be able to run the demo. Locate the USB flash drive shipped with your ML605 evaluation kit. Insert the USB drive into your PC and using Windows Explorer, navigate to the USB drive. You should see the following directory structure:

```
ML605_BRD_Application
ML605_BRD_Images
ML605_BRD_Src
Ready_For_Download
```

Note: As an option, you can copy all the necessary files, directories, and images to a local directory on a PC.

Navigate into the ML605_BRD_Application directory. In there you will find an install image, BaseRefDISetup2_0_6.msi. This is an application GUI that is used to display the graphical information for the Base Reference Design. Please double click on this application to install the software.



Figure 1-44: Run BRD GUI Installer

Click **Run**.

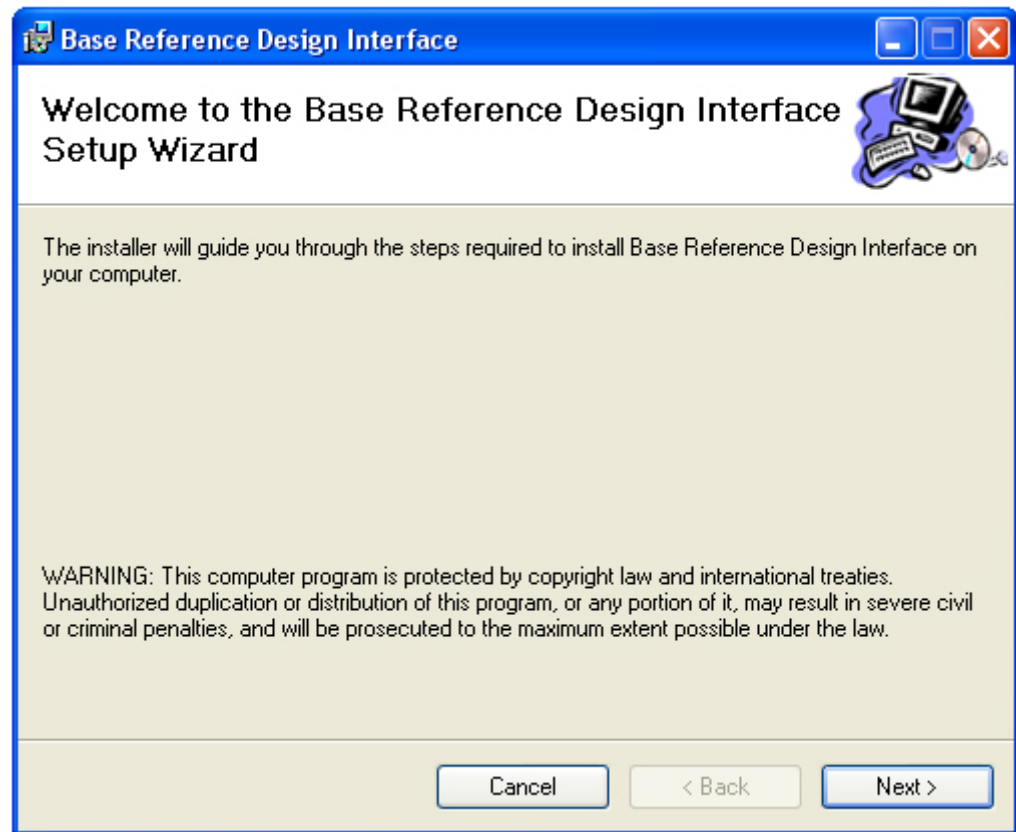

Figure 1-45: BRD Interface Setup

Click **Next** to run the BRD Setup Wizard.

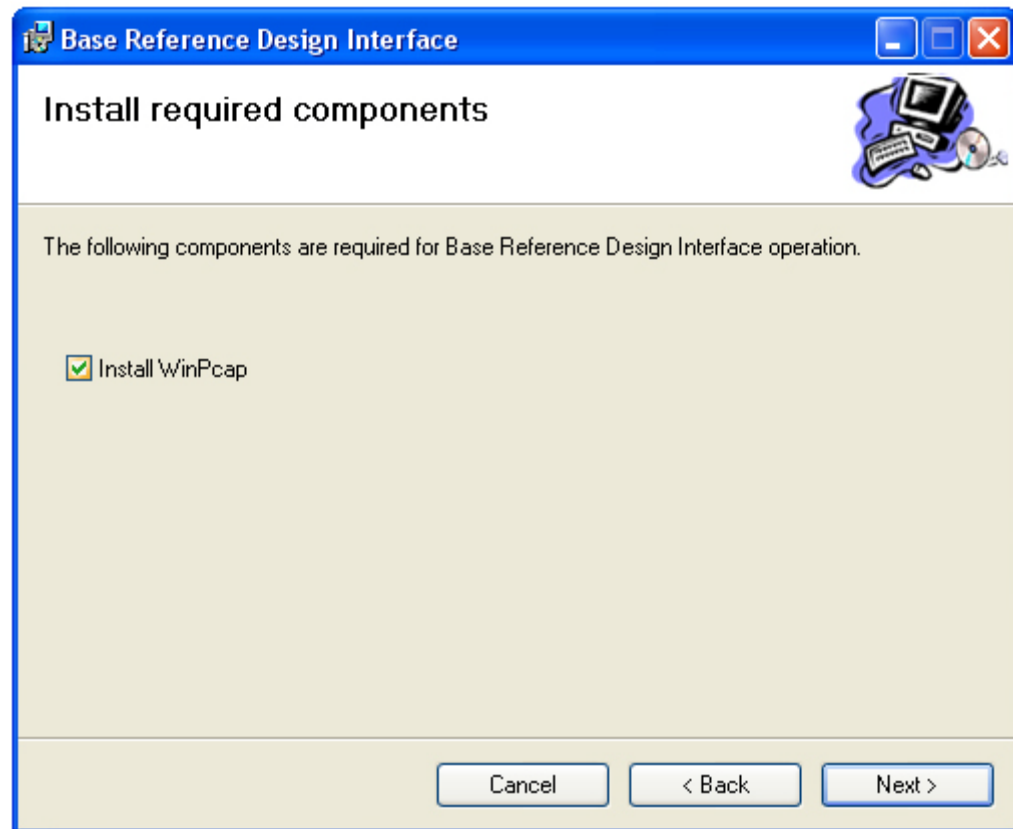

Figure 1-46: Install Required WinPcap Component

Click **Next**.

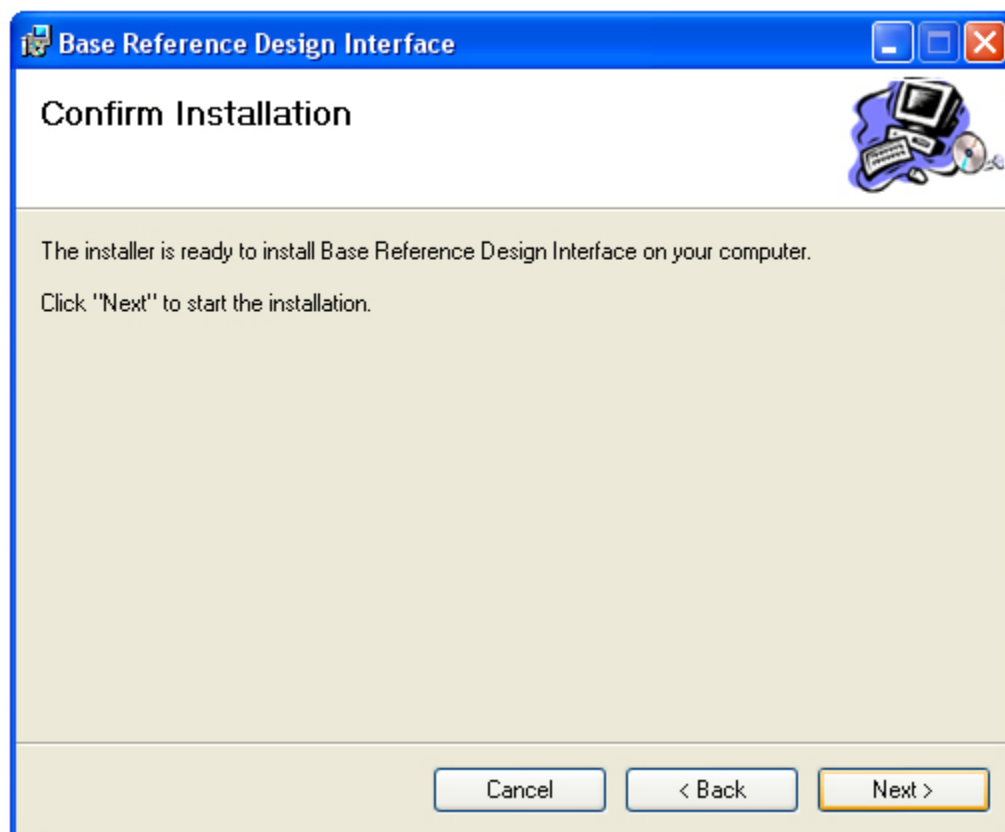

Figure 1-47: Confirm BRD Installation

Confirm the Installation by clicking **Next**.

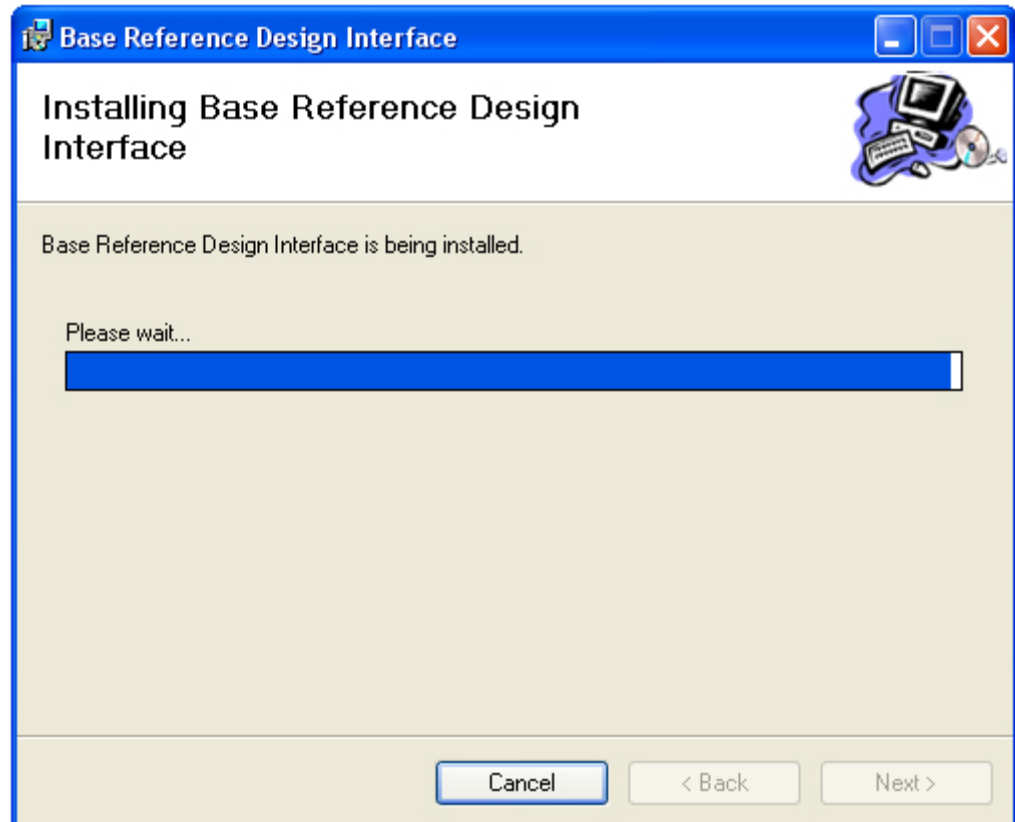

Figure 1-48: BRD Installation in Progress

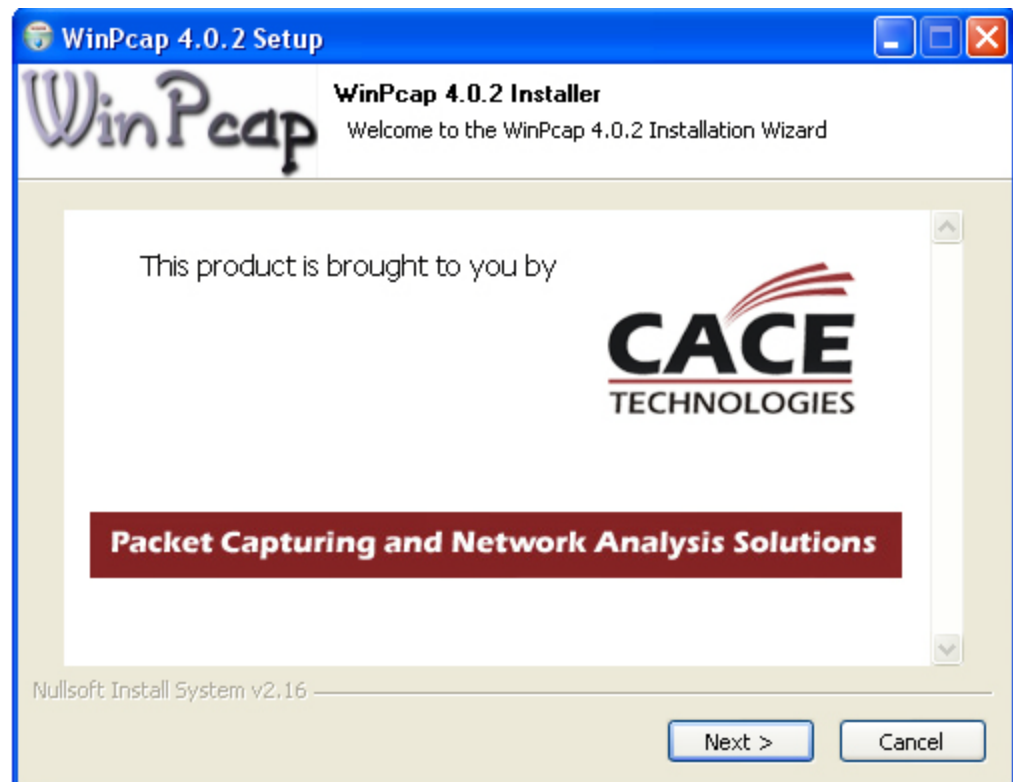

Figure 1-49: Launch WinPcap Installer

Click **Next**.

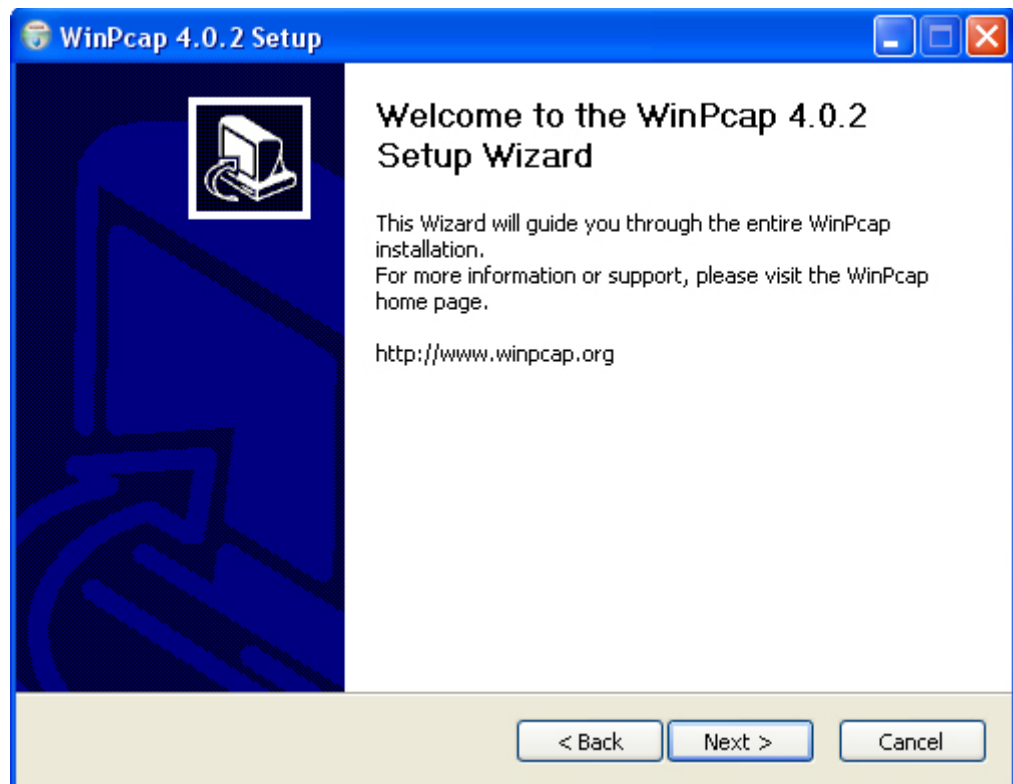

Figure 1-50: WinPcap Installation Wizard

Click **Next**.

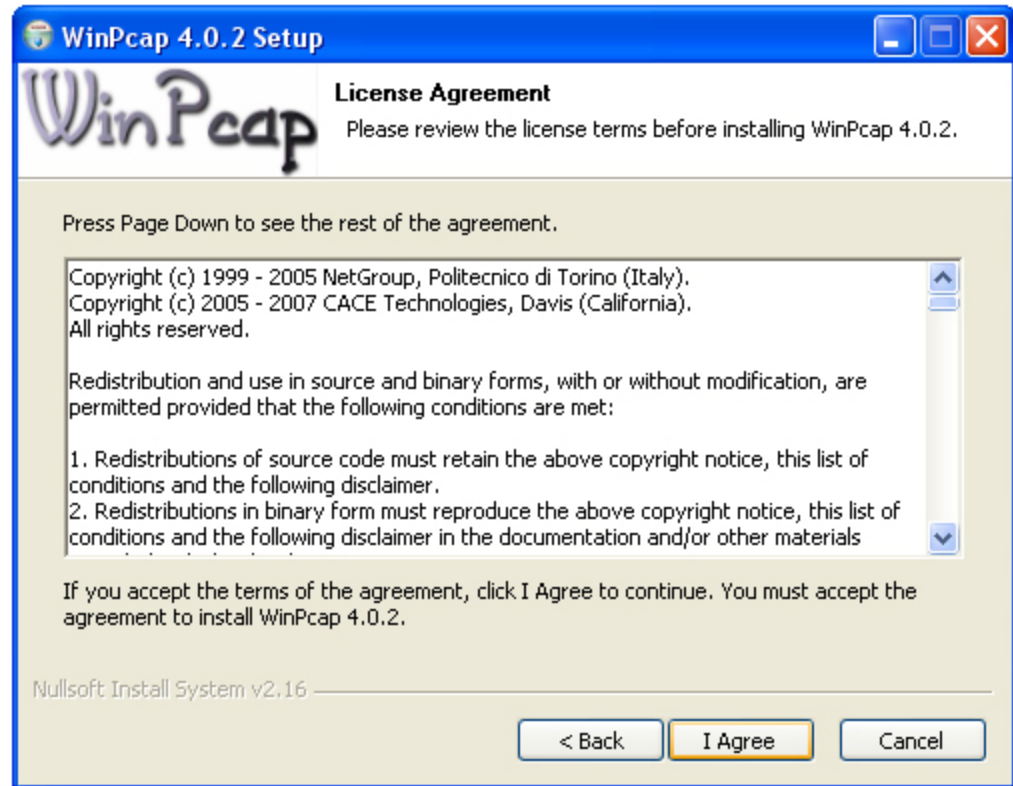

Figure 1-51: WinPcap License Agreement

Click **I Agree** if you agree with the WinPCAP license terms and conditions.

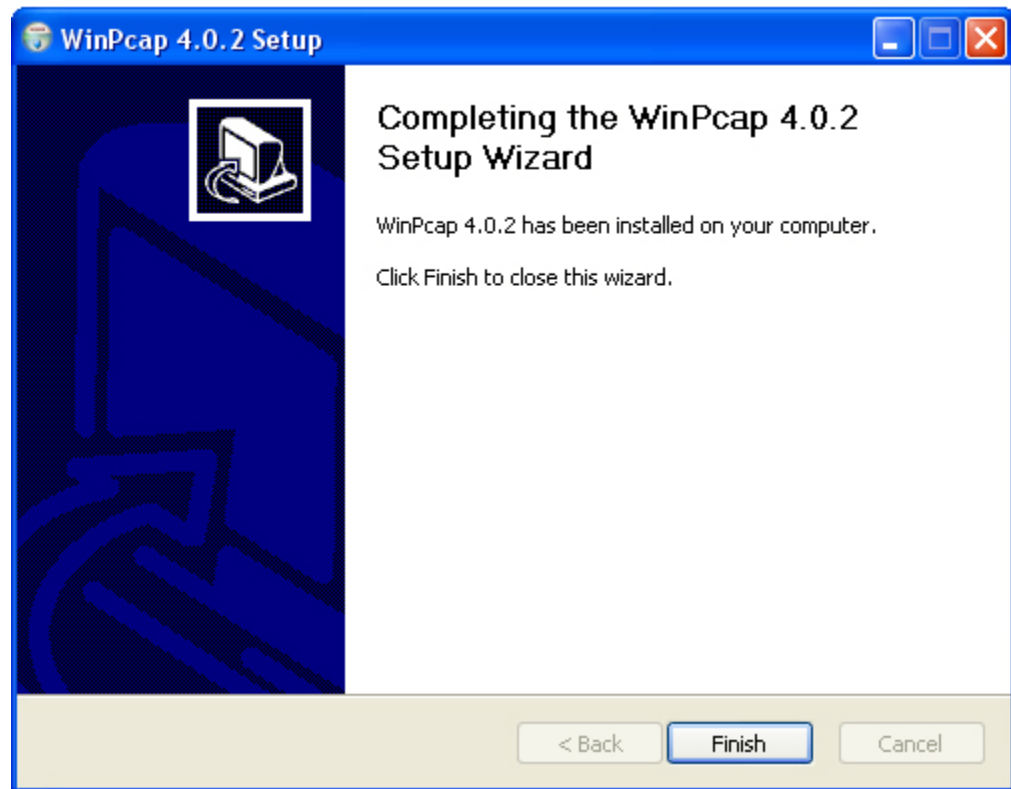

Figure 1-52: WinPcap Installation Wizard Successful

Click **Finish**.

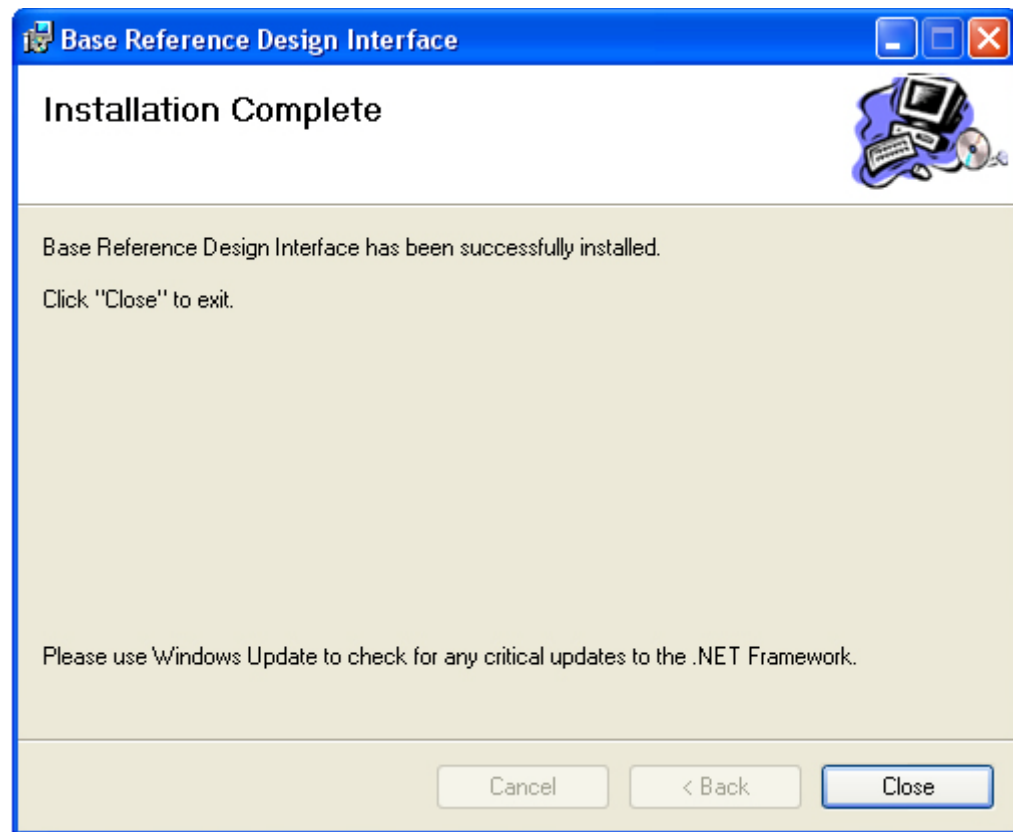

Figure 1-53: BRD Installation Complete

Click **Close**.

Running the Base Reference Design

Now that you have the ML605 set up and the Base Reference Design Application software installed, you can run the demo. You should have the Ethernet cable connected between the ML605 board and your PC Ethernet port.

Note: Turn off any wireless cards while running this demonstration.

To start the application GUI, please go to your Windows START menu and select **All Programs** → **XILINX** → **Base Reference Design** → **Base Reference Design Interface**

The GUI shown in [Figure 1-54](#) will start.

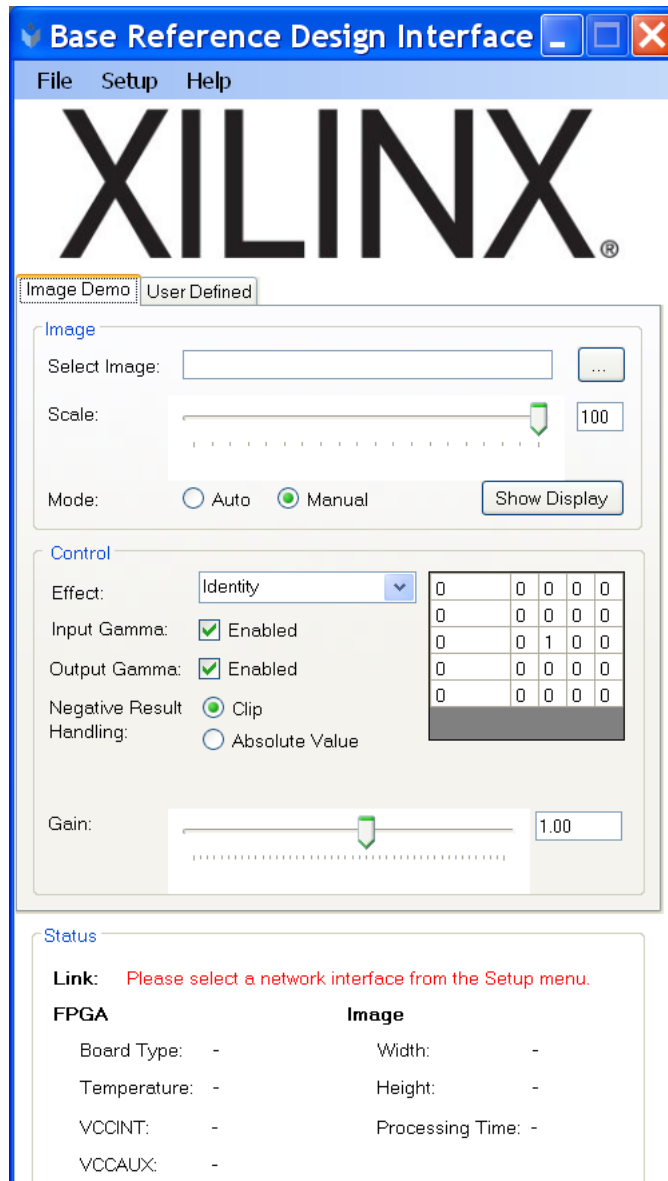

Figure 1-54: Network Link Setup Request

You will notice in the Status field at the bottom of the GUI that the Link needs to be set.

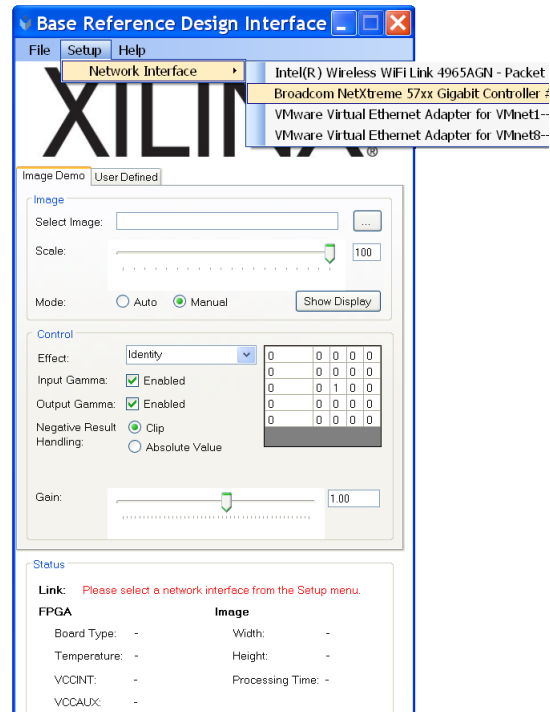

Figure 1-55: Setup Network Interface Connected to ML605

Select the menu item Setup, then select the appropriate Wired Network. Wait for few seconds and then press SW3 on the ML605 to configure the FPGA using the System ACE CF controller and the CompactFlash card.

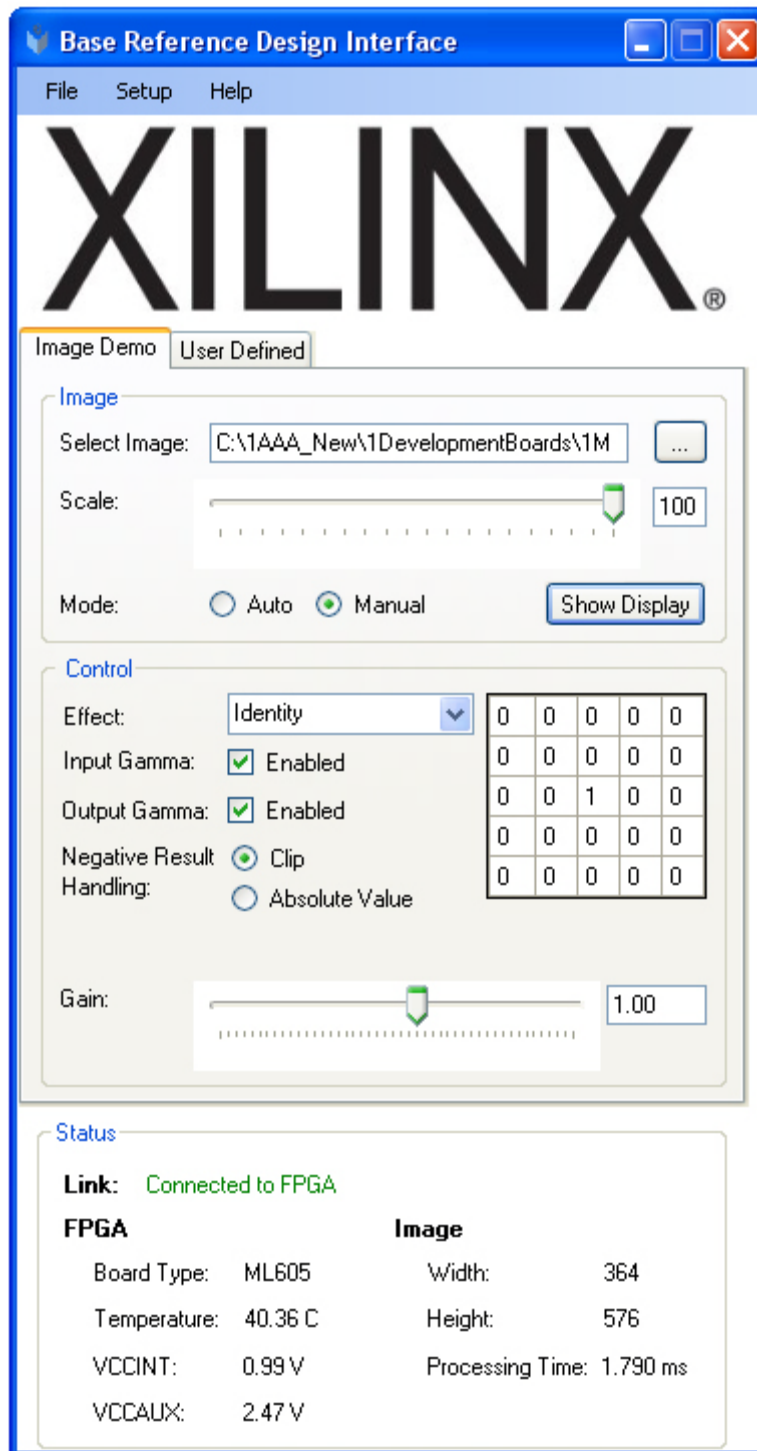

Figure 1-56: Successfully Connected to ML605

You can now select an image. It is best to select an image smaller than 1024 pixels wide. On the USB flash drive there are a number of images to select or you can select one of your

own images. To select one of the provided images, look in the ML605_BRD_Images directory.

In the Image section of the GUI, use the browse button to navigate to an image. After you have selected the image, click the Show Display button. This will display two side-by-side images. The leftmost image is the unaltered image, and the rightmost image is the image that has been filtered by the FPGA. Unless the effect has been changed, the default effect is Identity (Figure 1-57).

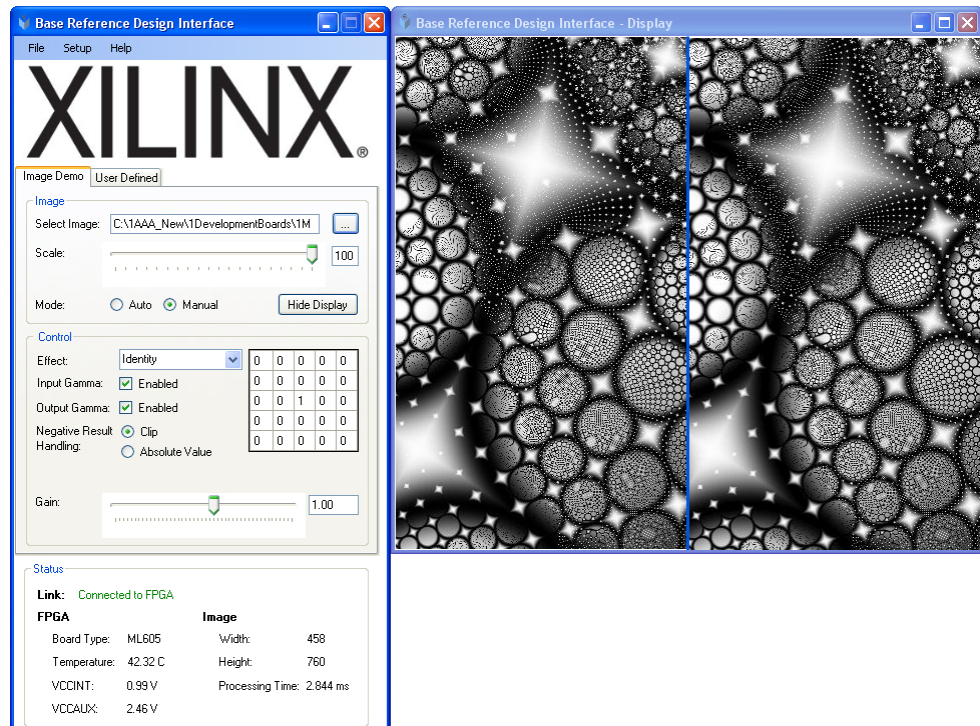

Figure 1-57: Original and FPGA Filtered Images using Identity Effect

Using the pull-down menu, select a different effect. For example, select SobelX. The filtering transform will display. As you can see in Figure 1-58, the image is updated using the selected filter operation.

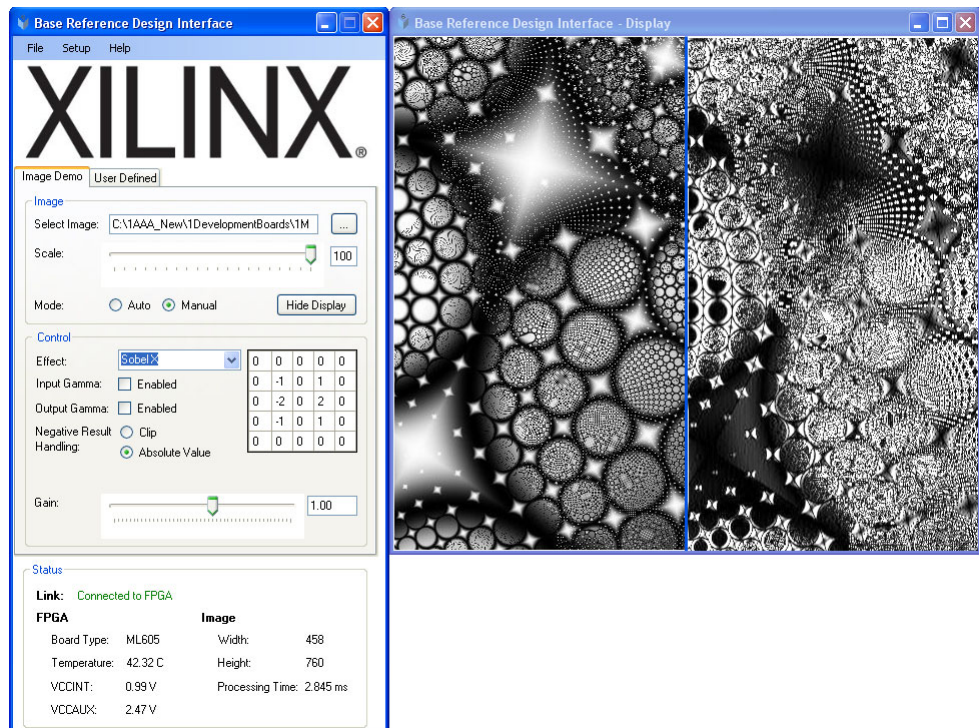

Figure 1-58: Original and FPGA Filtered Images using SobelX Effect

Select **Smooth effect** and notice how the 2-D FIR filter coefficient matrix values change. [Figure 1-59](#) shows how the image display changes as well.

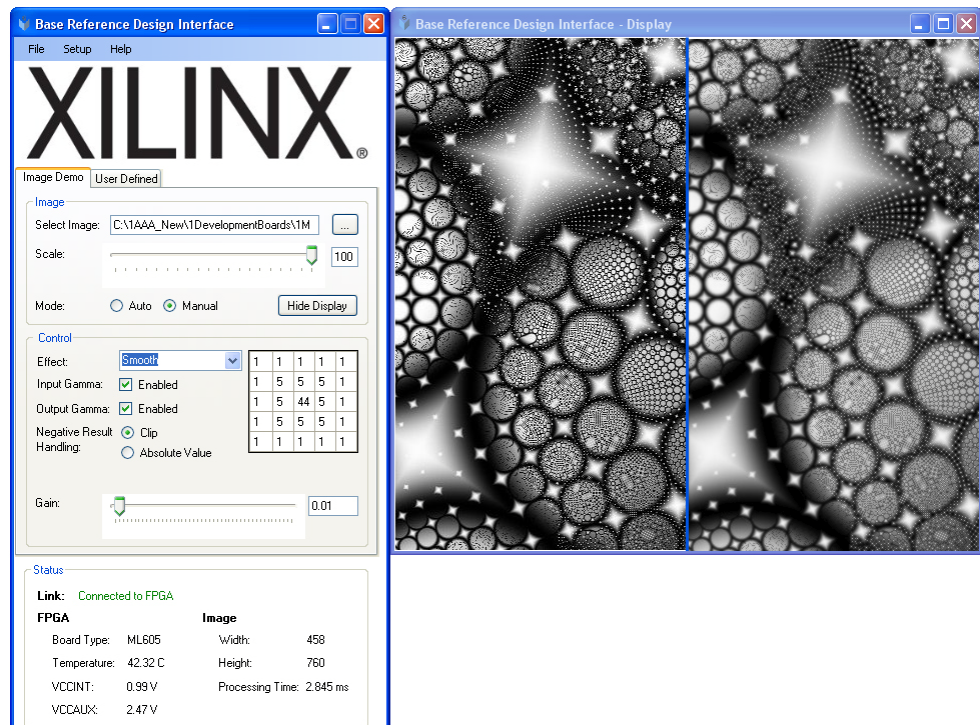

Figure 1-59: Original and FPGA Filtered Images using Smooth Effect

Choose Edge Detect from the effect menu. The filtering transform shown in Figure 1-60 will be displayed.

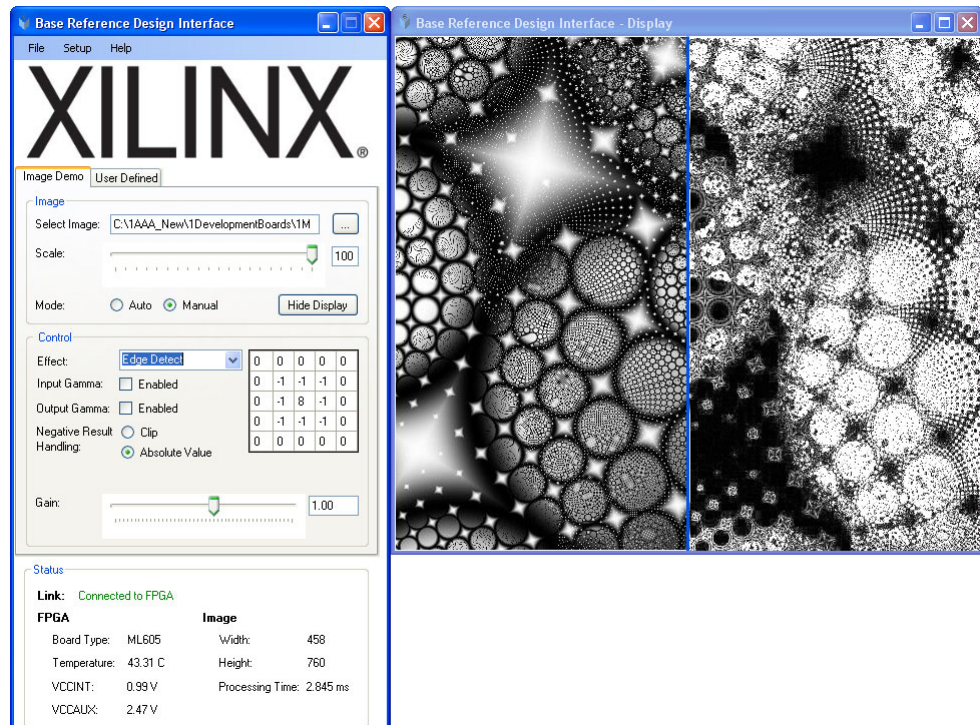

Figure 1-60: Original and FPGA Filtered Images using Edge Detect Effect

Different effects can be set automatically by selecting the **Auto** mode button.

FPGA temperature, VCCINT, VCCAUX, Image dimensions, and processing time are also reported by the Status field.

You have now completed running the reference design.

Installing the ISE Software

The ML605 evaluation kit includes entitlement to a seat that permits the ISE Design Suite: Logic Edition to be used with a Virtex-6 XC6VLX240T-1FFG1156C FPGA. This software can be installed from the DVD provided with the kit. The latest version can also be downloaded from <http://www.xilinx.com/support/download/index.htm>.

The ML605 evaluation kit also works with the software listed here:

- ISE Design Suite: Embedded Edition
- ISE Design Suite: DSP Edition
- ISE Design Suite: System Edition

Update the software before working with the evaluation kit. Updates can be downloaded from <http://www.xilinx.com/support/download/index.htm>

To install the ISE Design Suite: Logic Edition software from the DVD included with the ML605 evaluation kit:

1. Activate the software license. See “Redeeming the Software and IP License.”

2. Insert the DVD provided with the ML605 kit in the host computer's drive.
3. Follow the instructions provided by the installation software.

Redeeming the Software and IP License

A software voucher similar to the example shown in [Figure 1-61](#) is included with each ML605 evaluation kit. The voucher contains the code that is used to create a device-locked software license for the ISE software and/or the IP included with the evaluation kit.

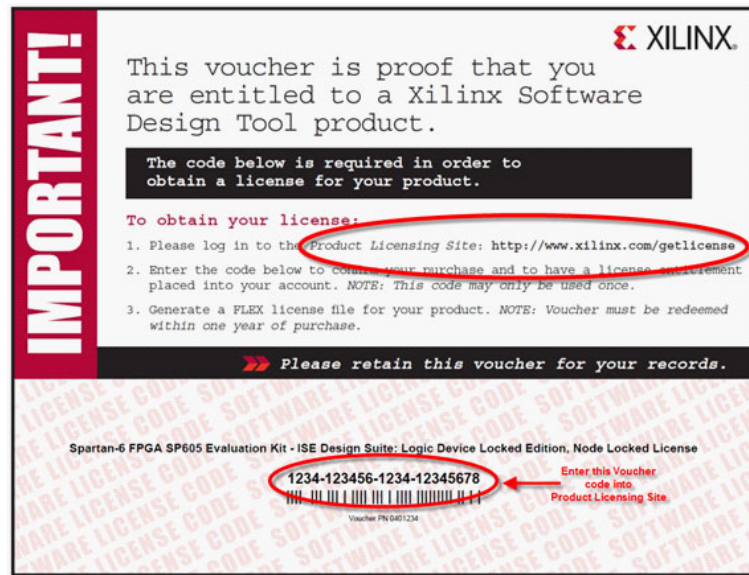

UG525_ct_21_110110

Figure 1-61: Software Voucher

To create a license:

1. Go to www.xilinx.com/getlicense/ (Figure 1-62).

Sign in Language Documentation Downloads Contact Us

XILINX

enter keywords Advanced Search

Product & Services Technology Solutions Market Solutions Support Buy Online About Xilinx

Sign in to the Xilinx Licensing Site

User ID

Password

[Forgot your password?](#)

Don't have a Xilinx account yet?

- > Choose to receive important news and product information
- > Gain access to special content
- > Personalize your web experience on Xilinx.com

Jobs Investors Feedback Legal Privacy Trademarks Sitemap

© Copyright 2010 Xilinx

UG525_c1_22_101410

Figure 1-62: Licensing Site Sign-In Page

2. If you have a Xilinx account, enter your **User ID**, **Password** and click **Sign In**. If you don't have an account, click **Create Account** to create one.

Note: If you have questions or need help, contact Xilinx customer service at: <http://www.xilinx.com/support/techsup/tappinfo.htm>.

3. After signing in, confirm your contact information is correct and click **Next**.
4. Under the **Create New Licenses** tab, enter the 22-digit code from the voucher in the field shown in [Figure 1-63](#). Click **Redeem Now**.

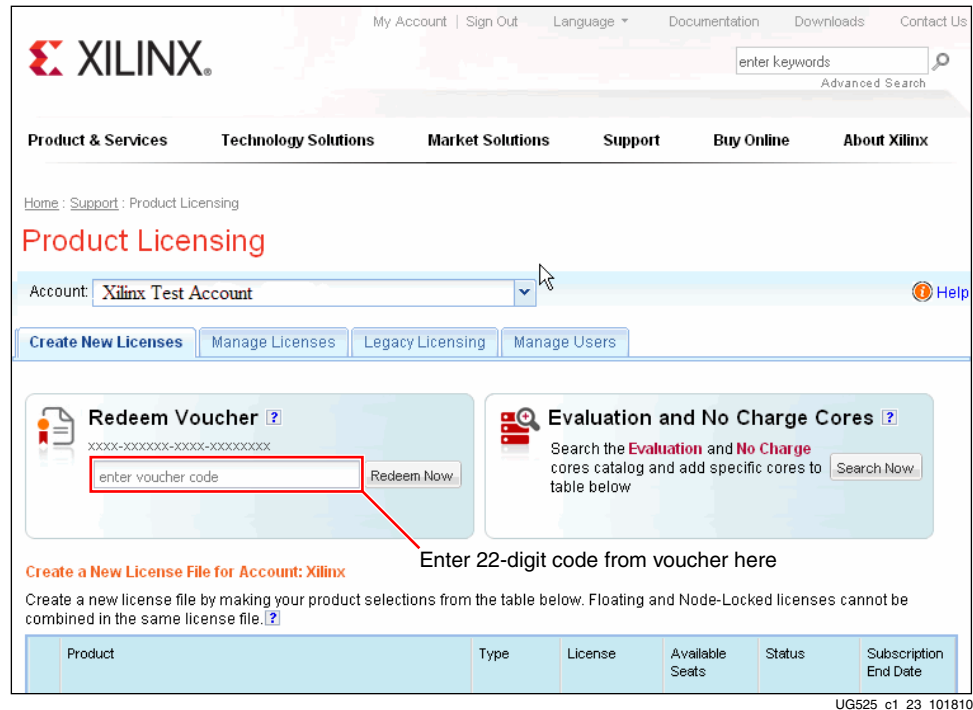

UG525_c1_23_101810

Figure 1-63: Redeem Voucher

The software represented by the voucher code is added to the product table and is selected (checked) for licensing as shown in Figure 1-64.

Note: The software descriptions shown in Figure 1-64 are examples and might differ from the descriptions shown on the actual page.

5. Click **Generate Node Locked License** at the bottom of the page to start the license generation flow (Figure 1-64).

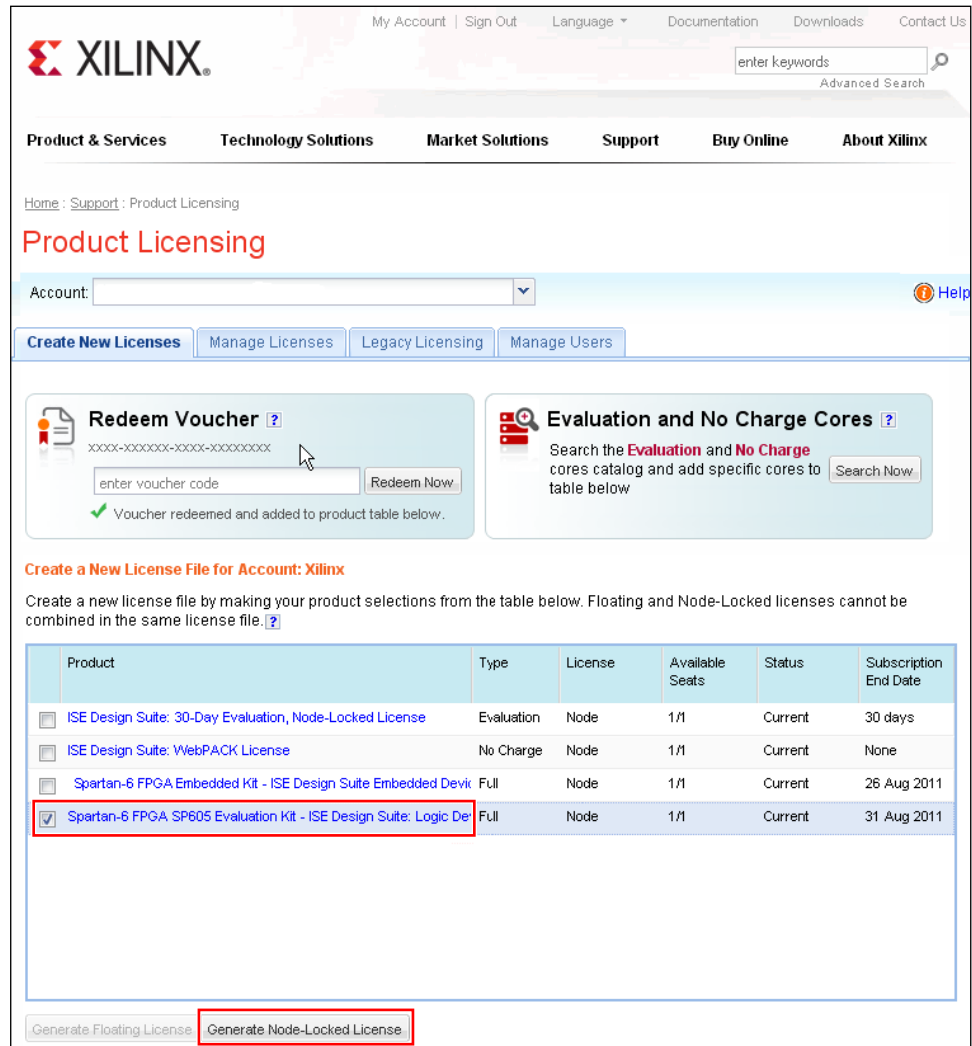
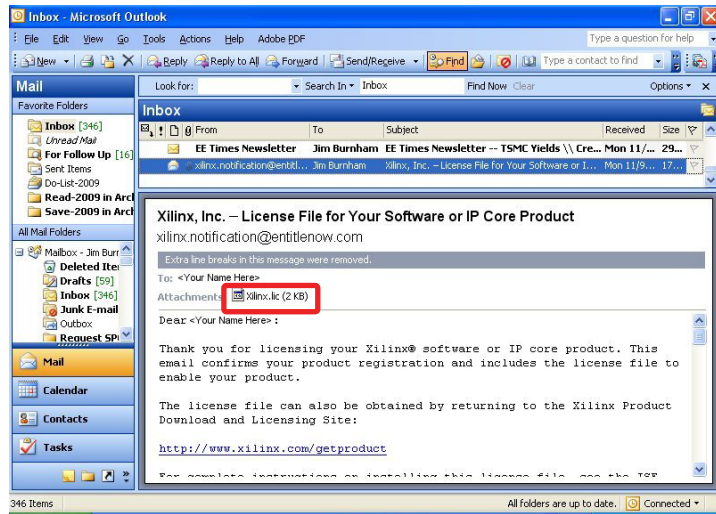

Figure 1-64: Generate License

6. When prompted to select a host name for the license, select a host ID. The host ID can be a dongle serial number, Ethernet MAC address, or a disk volume ID.
7. When license generation is complete, the license will be emailed to you. Follow the instructions in the Xilinx License email to complete the licensing process (Figure 1-65).



UG525_35_111209

Figure 1-65: Xilinx License Notification E-mail

8. Go back to the Xilinx License Configuration Manager dialog and click **Copy License...** (Figure 1-66).

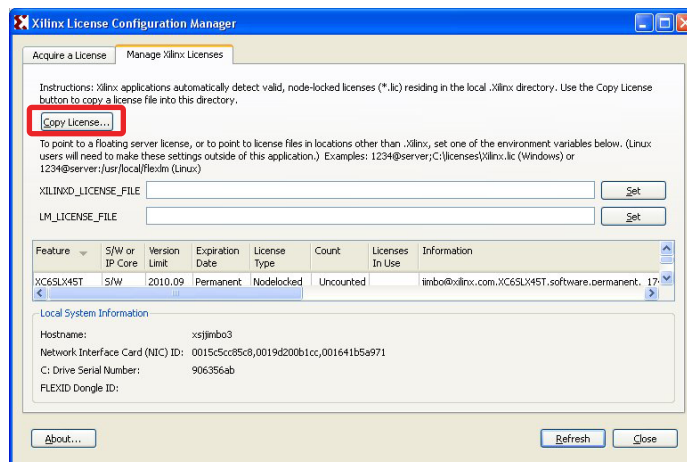

UG525_36_111209

Figure 1-66: Manage Xilinx License Tab

9. Navigate to the location where the `Xilinx.lc` file is saved and select it (Figure 1-67).

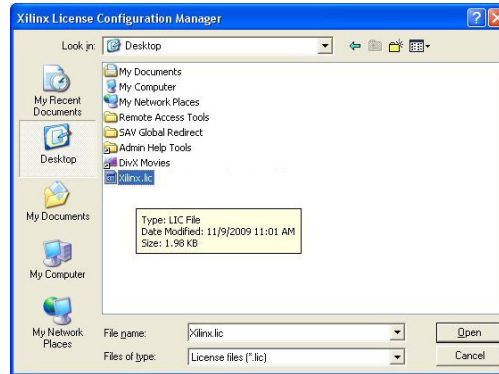
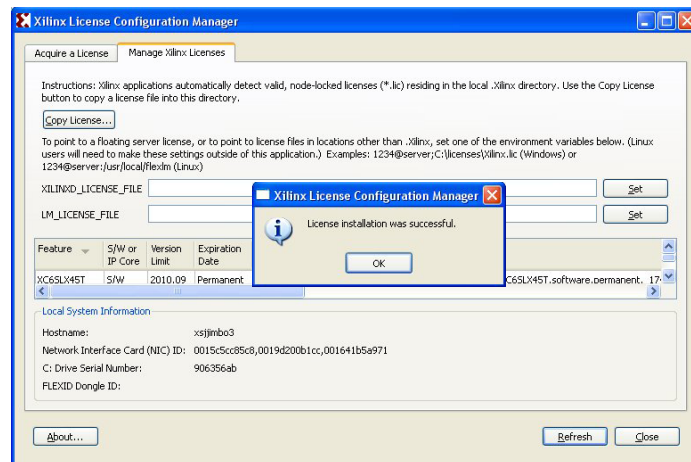

Figure 1-67: Select the `xilinx.lic` file

The ISE software license is now installed. Click **OK** on the Success Dialog (Figure 1-68) to close the Xilinx License Configuration Manager.



UG525_38_111209

Figure 1-68: License Installation Successful

Now What?

After following the steps in this Getting Started Guide, you can test the features of the board using the ML605 Board Diagnostic Flash and PCI Express demonstrations. You now have a complete and updated installation of the Xilinx ISE Device-Locked to Virtex-6 LX240T FPGA software, and should have been able to open your first project.

Additional resources are located on the ML605 product page at <http://www.xilinx.com/ml605>. You are encouraged to check the ML605 Evaluation Kit home page regularly for the latest in documentation, FAQs, reference design examples, product updates, and known issues.

Getting Additional Help and Support

Support

For questions regarding products within your Product Entitlement Account or if you feel you have received this notification in error, send an email message to your regional Customer Service Representative:

Canada, USA and South America - isscs_cases@xilinx.com

Europe, Middle East, and Africa - eucases@xilinx.com

Asia Pacific including Japan - apaccase@xilinx.com

For technical support including the installation and use of your product license file you may contact Xilinx Online Technical Support at www.support.xilinx.com. On this site you will also find the following resources for assistance:

Software, IP and Documentation Updates

Access to Technical Support Web Tools

Searchable Answer Database with Over 4,000 Solutions

User Forums

Warranty

THIS LIMITED WARRANTY applies solely to standard hardware development boards and standard hardware programming cables manufactured by or on behalf of Xilinx (“Development Systems”). Subject to the limitations herein, Xilinx warrants that Development Systems, when delivered by Xilinx or its authorized distributor, for ninety (90) days following the delivery date, will be free from defects in material and workmanship and will substantially conform to Xilinx publicly available specifications for such products in effect at the time of delivery. This limited warranty excludes: (i) engineering samples or beta versions of Development Systems (which are provided “AS IS” without warranty); (ii) design defects or errors known as “errata”; (iii) Development Systems procured through unauthorized third parties; and (iv) Development Systems that have been subject to misuse, mishandling, accident, alteration, neglect, unauthorized repair or installation. Furthermore, this limited warranty shall not apply to the use of covered products in an application or environment that is not within Xilinx specifications or in the event of any act, error, neglect or default of Customer. For any breach by Xilinx of this limited warranty, the exclusive remedy of Customer and the sole liability of Xilinx shall be, at the option of Xilinx, to replace or repair the affected products, or to refund to Customer the price of the affected products. The availability of replacement products is subject to product discontinuation policies at Xilinx. Customer may not return product without first obtaining a customer return material authorization (RMA) number from Xilinx.

THE WARRANTIES SET FORTH HEREIN ARE EXCLUSIVE. XILINX DISCLAIMS ALL OTHER WARRANTIES, WHETHER EXPRESS, IMPLIED OR STATUTORY, INCLUDING, WITHOUT LIMITATION, ANY WARRANTY OF MERCHANTABILITY, FITNESS FOR A PARTICULAR PURPOSE, OR NON-INFRINGEMENT, AND ANY WARRANTY THAT MAY ARISE FROM COURSE OF DEALING, COURSE OF PERFORMANCE, OR USAGE OF TRADE. (2008.10)



Do not throw Xilinx products marked with the “crossed out wheeled bin” in the trash. Directive 2002/96/EC on waste electrical and electronic equipment (WEEE) requires the separate collection of WEEE. Your cooperation is essential in ensuring the proper management of WEEE and the protection of the environment and human health from potential effects arising from the presence of hazardous substances in WEEE. Return the marked products to Xilinx for proper disposal. Further information and instructions for free-of-charge return available at: <http://www.xilinx.com/ehs/weee.htm>.

References

This section provides references to documentation supporting Virtex-6 FPGAs, tools, and IP. For additional information, see www.xilinx.com/support/documentation/index.htm.

1. [UG534](#), *ML605 Hardware User Guide*
2. [UG535](#), *ML605 Reference Design User Guide*
3. [DS150](#), *Virtex-6 Family Overview*
4. [DS152](#), *Virtex-6 FPGA Data Sheet: DC and Switching Characteristics*
5. [UG360](#), *Virtex-6 FPGA Configuration User Guide*
6. [UG361](#), *Virtex-6 FPGA SelectIO Resources User Guide*
7. [UG362](#), *Virtex-6 FPGA User Guide: Clocking Resources*
8. [UG363](#), *Virtex-6 FPGA Memory Resources User Guide*
9. [UG364](#), *Virtex-6 FPGA Configurable Logic Block User Guide*
10. [UG365](#), *Virtex-6 FPGA Packaging and Pinout Specifications*
11. [UG366](#), *Virtex-6 FPGA GTX Transceivers User Guide*
12. [UG369](#), *Virtex-6 FPGA DSP48E1 Slice User Guide*
13. [DS186](#), *Virtex-6 FPGA Memory Interface Solutions Data Sheet*
14. [UG370](#), *Virtex-6 FPGA System Monitor User Guide*
15. [DS643](#), *Multi-Port Memory Controller (MPMC) (v5.02a) Data Sheet*
16. [UG086](#), *Memory Interface Solutions User Guide*
17. [UG138](#), *LogiCORE™ IP Tri-Mode Ethernet MAC v4.3 User Guide*
18. [UG517](#), *LogiCORE™ IP Virtex-6 FPGA Integrated Block User Guide v1.3 for PCI Express*
19. [DS715](#), *Virtex-6 FPGA Integrated Block v1.3 for PCI Express Data Sheet*
20. [Platform Studio EDK](#)

ML605 tutorials and design files are located at http://www.xilinx.com/products/boards/ml605/reference_designs.htm:

21. *ML605 Built-In Self Test Flash Application*
22. *ML605 MIG Design Creation*
23. *ML605 PCIe x8 Gen1 Design Creation*
24. *ML605 PCIe x4 Gen2 Design Creation*
25. *ML605 MultiBoot Design*
26. *ML605 GTX IBERT Design Creation*
27. *ML605 System Monitor*
28. *ML605 Restoring Flash Contents*

